

# MOPAR COMPACT TANDEM MASTER CYLINDER

## SPECIFICATION SHEET • INSTRUCTIONS



Master cylinder  
p/n 260-16791-P shown

### Master Cylinder Part Numbers

- 260-16791-P/-BK – 0.94" Piston, w/ pushrod**
- 260-16792-P/-BK – 1.00" Piston**
- 260-16854-P/-BK – 1.00" Piston, w/ pushrod**
- 260-16793-P/-BK – 1.12" Piston**

Component	Specifications
Piston - Bore Diameter.....	.94, 1.00, 1.12 in.
Piston Stroke - Push Rod Travel.....	1.10 in.
Primary (A) Reservoir Capacity.....	14.0 cubic in.
Secondary (B) Reservoir Capacity.....	8.5 cubic in.
Volume Output Ratio (A:B).....	2:1
Pressure Output Ratio (A/B).....	50/50

### Installation Notes and Precautions

**•WARNING:**

*The master cylinder push rod must bottom out in the bore before the pedal stops against the floorboard. The inherent safety feature of tandem master cylinders is the ability to still build pressure in one circuit if the other fails. In the event of a circuit failure, the push rod (and pedal) may travel 50% - 80% of the total stroke before starting to build pressure in the other circuit, allowing emergency braking to stop the vehicle.*

*To take advantage of this safety feature, before adding brake fluid to the system, assure that the push rod will travel its full stroke (1.10") before the pedal stops against the floorboard (with insulation, padding, and carpet) or any other stop point. If not, adjustments need to be made to the pushrod, pedal, and/or pedal mount to allow full push rod travel.*

*This master cylinder may not work in all applications and it is the installer's responsibility to determine suitability and assure full push rod travel.*

•Check the length and diameter of the push rod from the pedal or power booster. It should fully engage the bottom of the recess in the master cylinder piston assembly without interference along the sides or shoulders. For short push rod power brake boosters, use the spacer supplied to reduce the overall depth of the piston recess. The piston detail diagram on the next page illustrates the overall depth and diameter of the push-rod recess.

•When the pedal is released, the piston assembly must fully return to the snap-ring retainer at the end of the cylinder bore. Consequently, the push rod must be long enough to remain captured inside the piston recess when the pedal is fully retracted. Adjust the length of the push rod and available pedal travel as necessary. Return springs and pedal stops are always recommended.

•Always mount the master cylinder to a secure, reinforced element of the chassis. There should be no movement or deflection at the mount point when brake pedal pressure is applied.

**WARNING**

IT IS THE RESPONSIBILITY OF THE PERSON INSTALLING ANY BRAKE COMPONENT OR KIT TO DETERMINE THE SUITABILITY OF THE COMPONENT OR KIT FOR THAT PARTICULAR APPLICATION. IF YOU ARE NOT SURE HOW TO SAFELY USE THIS BRAKE COMPONENT OR KIT, YOU SHOULD NOT INSTALL OR USE IT. DO NOT ASSUME ANYTHING. IMPROPERLY INSTALLED OR MAINTAINED BRAKES ARE DANGEROUS. IF YOU ARE NOT SURE, GET HELP OR RETURN THE PRODUCT. YOU MAY OBTAIN ADDITIONAL INFORMATION AND TECHNICAL SUPPORT BY CALLING WILWOOD AT (805) 388-1188, OR VISIT OUR WEB SITE AT WWW.WILWOOD.COM. USE OF WILWOOD TECHNICAL SUPPORT DOES NOT GUARANTEE PROPER INSTALLATION. YOU, OR THE PERSON WHO DOES THE INSTALLATION MUST KNOW HOW TO PROPERLY USE THIS PRODUCT. IT IS NOT POSSIBLE OVER THE PHONE TO UNDERSTAND OR FORESEE ALL THE ISSUES THAT MIGHT ARISE IN YOUR INSTALLATION.

RACING EQUIPMENT AND BRAKES MUST BE MAINTAINED AND SHOULD BE CHECKED REGULARLY FOR FATIGUE, DAMAGE, AND WEAR.

## Bench Bleeding Master Cylinder

•Prior to attaching the vehicle's fluid lines, it is necessary to fill the master cylinder with brake fluid and purge the air. We recommend following the instructions below to bench bleed the master cylinder. The same method can be used with the master cylinder mounted in the vehicle provided that the master cylinder reaches full travel BEFORE the pedal contacts the floor or firewall. Master cylinder must be level for proper bleeding.

1. Clamp master cylinder securely by the mounting flange in a bench vise.
2. Thread plastic fittings into the outlet ports of the master cylinder, and tighten with wrench. Press clear tubes onto fittings and route other ends of tubes into each of the master cylinder reservoirs. Secure the tubes using the provided clip to make sure they stay in place.
3. Fill the reservoir with new brake fluid to approximately 1" from the top. Be sure the ends of the tubes are covered by the brake fluid.
4. Push the piston into the bore until it reaches full stroke. Repeat the process until bubbles are no longer present in the clear plastic tubes. This should be achieved fairly quickly, usually with a few strokes. If not, the plastic fittings may not be tight enough. **NOTE:** A small amount of tiny air bubbles in the tubes is generally okay and should be expelled during the system bleeding process.
5. Remove master cylinder from vise and install on vehicle.
6. Now remove the bleeder tubes and nuts for the outlet ports and attach the vehicle's brake lines. Exercise care to not spill or spray brake fluid. Take all proper safety precautions including eye and skin protection and do not position your face directly above the reservoir. This process will assure a quick and effective full system bleed.
7. Once all fluid connections have been made, the complete system must be bled to remove any remaining air. Refer to the Service Manual or the 'Bleeding the Brake System' section on the next page for the proper bleeding procedure. Check system for leaks prior to any test of the vehicle.

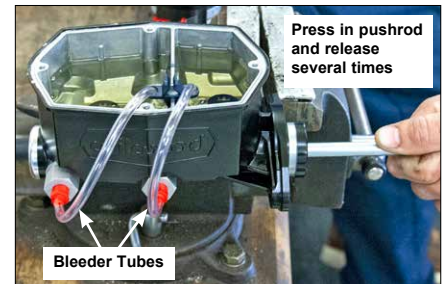

Typical Bleeder Tube Setup and Use

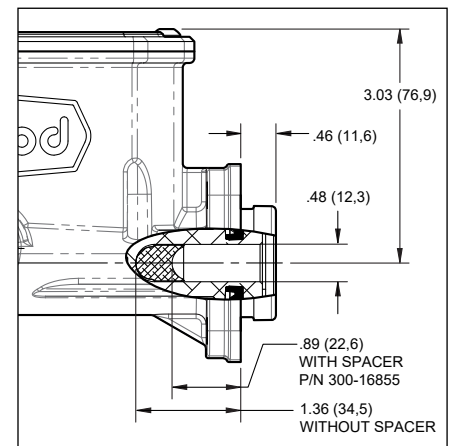

Master Cylinder Piston Detail

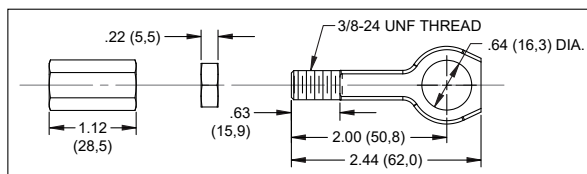
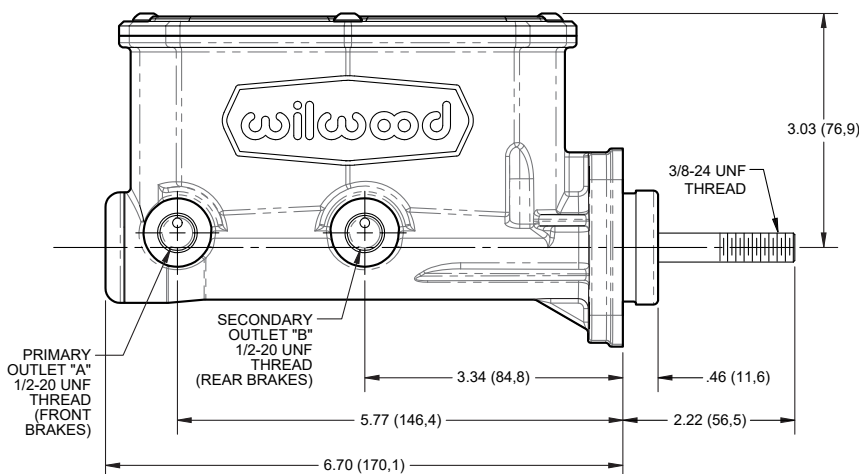

MOPAR PUSH ROD - EYELET DETAIL

NOTE: PUSHROD & EYELET INCLUDED WITH P/N 260-16791 & 260-16854

### OUTLET FITTING REQUIREMENT

OUTLET "A"	OUTLET "B"
220-8574 or 220-8949 (w/ P-Valve)	220-16740 or 220-8949 (w/ P-Valve)

**WARNING:** Outlets are reversed from factory original master cylinders

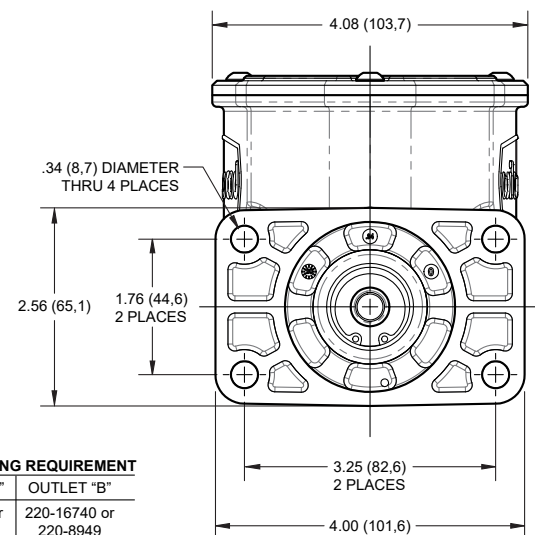

## Wilwood Dual Outlet Compact Tandem Chamber Master Cylinder, Mounting Dimensions

### WARNING

THIS COMPONENT IS DESIGNED FOR USE IN CUSTOM BRAKE SYSTEMS ON PERFORMANCE, RACING, AND OTHER SPECIAL PURPOSE BUILT OFF-ROAD VEHICLES. IT IS NOT INTENDED AS A DIRECT REPLACEMENT FOR ANY OEM APPLICATION.

## Plumbing Notes and Precautions

- Each master cylinder kit includes one 9/16-20, one 1/2-20, and two 3/8-24 inverted flare threaded line adapters for connections to the brake lines (adapters are not installed and are shipped in the reservoir of the master cylinder, remove lid to access). Two hex head plugs are supplied to block the unused outlet ports. Pressure may be taken from either side of the master cylinder. After selecting the size and location of the outlet ports to be used, install the fittings and plugs, using the aluminum crush washers and torque each to 20-25 foot pounds.
- The line adapters supplied with each master cylinder are for use with double flared brake line. Use only double flared lines. Do not attempt to use single flared connections. Do not use additional sealant or any other type of gaskets on the fittings, lines, or plugs.
- Connect one of the primary outlet ports (A) (see Mounting Dimensions diagram on previous page) to the brakes at the end of the vehicle with the greatest total effective piston bore area. On most vehicles, this will be the front brake line (see info below on calculating piston bore area).
- Connect one of the secondary outlet ports (B) (see Mounting Dimensions diagram on previous page) to the brakes at the end of the vehicle with the lesser total effective piston bore area. On most vehicles, this will be the rear brake line (see info below on calculating piston bore area).
- Use of reinforced flexible lines should be limited to the connection between the fixed chassis and the moving suspension. All other lines along the fixed chassis should be hard steel lines.
- On four wheel disc brake applications, where the fluid reservoir is mounted higher than the caliper bleed screws, a residual pressure valve is usually not required.
- On disc brake applications where the fluid reservoir is mounted lower than the caliper bleed screws may require a 2 or 4 pound residual pressure valve. This can prevent fluid drain back and excessive pedal travel on initial engagement.
- All drum brake applications require an inline 10 pound residual pressure valve.
- Use an adjustable proportioning valve to set the front to rear brake bias.

### CALCULATING EFFECTIVE PISTON BORE AREA TO DETERMINE PLUMBING

To determine the effective piston bore area of any caliper, you must first calculate the area for each piston bore found on one side of the caliper. Use the formula "Area = (bore x bore) x .785" for each piston bore size. Then, add the areas of all pistons on that one side of the caliper to determine the total effective piston bore area. Compare the difference between the front and rear calipers and attach the line from the primary outlet "A" to the calipers at the end of the vehicle with the greater total effective piston bore area.

## Bleeding the Brake System

- Fill and bleed the new system with Wilwood Hi-Temp° 570 grade fluid or higher. For severe braking or sustained high heat operation, use Wilwood EXP 600 Plus Racing Brake Fluid. Used fluid must be completely flushed from the system to prevent contamination. **NOTE: Silicone DOT 5 brake fluid is NOT recommended for racing or performance driving.**
- To properly bleed the brake system, begin with the caliper farthest from the master cylinder. Bleed the outboard bleed screw first, then the inboard. Repeat the procedure until all calipers in the system are bled, ending with the caliper closest to the master cylinder. **NOTE: When using a new master cylinder, it is important to bench bleed the master cylinder first.**
- Test the brake pedal. It should be firm, not spongy and stop at least 1 inch from the floor under heavy load.
  - If the brake pedal is spongy, bleed the system again.
  - If the brake pedal is initially firm, but then sinks to the floor, check the system for fluid leaks. Correct the leaks (if applicable) and then bleed the system again.
  - If the brake pedal goes to the floor and continued bleeding of the system does not correct the problem, a master cylinder with increased capacity (larger bore diameter) may be required. Wilwood offers various lightweight master cylinders with large fluid displacement capacities.
- If after following the instructions, you still have difficulty bleeding your disc brakes, consult your local chassis builder, or retailer where the kit was purchased for further assistance. Additional information is also available on our web site at [www.wilwood.com](http://www.wilwood.com), or e-mail technical assistance: [info@wilwood.com](mailto:info@wilwood.com).

**WARNING • DO NOT DRIVE ON UNTESTED BRAKES**  
**BRAKES MUST BE TESTED AFTER INSTALLATION OR MAINTENANCE**  
**MINIMUM TEST PROCEDURE**

- Make sure pedal is firm: Hold firm pressure on pedal for several minutes, it should remain in position without sinking. If pedal sinks toward floor, check system for fluid leaks. DO NOT drive vehicle if pedal does not stay firm or can be pushed to the floor with normal pressure.
- At very low speed (2-5 mph) apply brakes hard several times while turning steering from full left to full right, repeat several times. Remove the wheels and check that components are not touching, rubbing, or leaking.
- Carefully examine all brake components, brake lines, and fittings for leaks and interference.
- Make sure there is no interference with wheels or suspension components.
- Drive vehicle at low speed (15-20 mph) making moderate and hard stops. Brakes should feel normal and positive. Again check for leaks and interference.
- Always test vehicle in a safe place where there is no danger to (or from) other people or vehicles.
- Always wear seat belts and make use of all safety equipment.

**REBUILD NOTE:**

WILWOOD TANDEM MASTER CYLINDERS ARE NOT USER SERVICEABLE DUE TO THE NECESSITY OF SPECIAL TOOLS FOR DISASSEMBLY. IN THE EVENT REBUILDING SERVICE IS REQUIRED, PLEASE CONTACT WILWOOD TECHNICAL DEPARTMENT AT (805) 388-1188 TO ARRANGE FOR RETURNING MASTER CYLINDER FOR FACTORY REBUILD AND/OR REPAIR AT A NOMINAL COST.

## Components and Accessories

<u>Part No.</u>	<u>Description</u>	<u>Part No.</u>	<u>Description</u>
260-13706	2 PSI Residual Pressure Valve	290-0632	Wilwood Hi-Temp 570 DOT 3 Fluid
260-15365	4 PSI Residual Pressure Valve	290-6209	Wilwood EXP 600 Plus Super Hi-Temp Fluid
260-13707	10 PSI Residual Pressure Valve		
260-8419	Knob Adjustable Proportioning Valve		
260-8420	Lever Adjustable Proportioning Valve		