

INSTALLATION INSTRUCTIONS
FOR
FORWARD MOUNT
DUAL STEEL PEDAL ASSEMBLY

PART NUMBER
340-6916

**DISC BRAKES SHOULD ONLY BE INSTALLED BY SOMEONE
EXPERIENCED AND COMPETENT IN THE INSTALLATION AND
MAINTENANCE OF DISC BRAKES**
READ ALL WARNINGS

WARNING

IT IS THE RESPONSIBILITY OF THE PERSON INSTALLING ANY BRAKE COMPONENT OR KIT TO DETERMINE THE SUITABILITY OF THE COMPONENT OR KIT FOR THAT PARTICULAR APPLICATION. IF YOU ARE NOT SURE HOW TO SAFELY USE THIS BRAKE COMPONENT OR KIT, YOU SHOULD NOT INSTALL OR USE IT. DO NOT ASSUME ANYTHING. IMPROPERLY INSTALLED OR MAINTAINED BRAKES ARE DANGEROUS. IF YOU ARE NOT SURE, GET HELP OR RETURN THE PRODUCT. YOU MAY OBTAIN ADDITIONAL INFORMATION AND TECHNICAL SUPPORT BY CALLING WILWOOD AT (805) 388-1188, OR VISIT OUR WEB SITE AT WWW.WILWOOD.COM. USE OF WILWOOD TECHNICAL SUPPORT DOES NOT GUARANTEE PROPER INSTALLATION. **YOU**, OR THE PERSON WHO DOES THE INSTALLATION MUST KNOW HOW TO PROPERLY USE THIS PRODUCT. IT IS NOT POSSIBLE OVER THE PHONE TO UNDERSTAND OR FORESEE ALL THE ISSUES THAT MIGHT ARISE IN YOUR INSTALLATION.

RACING EQUIPMENT AND BRAKES MUST BE MAINTAINED AND SHOULD BE CHECKED REGULARLY FOR FATIGUE, DAMAGE, AND WEAR.



Need Additional Information?
Use Your SmartPhone and
Jump to Our Technical Tips
Section on Our Web Site.



WARNING

DO NOT OPERATE ANY VEHICLE ON UNTESTED BRAKES!
SEE MINIMUM TEST PROCEDURE WITHIN

ALWAYS UTILIZE SAFETY RESTRAINT SYSTEMS AND ALL OTHER AVAILABLE SAFETY EQUIPMENT WHILE OPERATING THE VEHICLE

IMPORTANT • READ THE DISCLAIMER OF WARRANTY INCLUDED IN THE KIT

NOTE: Some cleaners may stain or remove the finish on brake system components. Test the cleaner on a hidden portion of the component before general use.

General Information and Assembly Instructions

Installation of this component should **ONLY** be performed by persons experienced in the installation and proper operation of disc brake systems. Before assembly begins, familiarize yourself with the following procedure to ensure a trouble-free installation.

Features:

- Lightweight construction, only 4.12 pounds.
- High strength computer design.
- Includes brake balance bar.
- Brake and clutch pedal have 6.25:1 ratio.
- High strength steel master cylinder mounting studs.
- Easy mounting location.
- Non-slip pedals.
- Fully anodized finish.
- Finest quality hardware.
- Use with Wilwood remote, high volume aluminum or composite master cylinders.

Installation Instructions:

Wilwood's forward mount dual steel pedal assembly must be mounted using the four outboard tab mounting holes. Attach the pedal assembly to two sturdy beams or plates with four 5/16 inch bolts. Pedal assembly must be rigidly attached to frame and not deflect under heavy pedal forces. Pedals must be free from obstructions over their entire range of motion. Allow enough space so balance bar adjustments can be made and masters cylinders are accessible.



Part Number 340-6916
(Shown w/Master Cylinders)

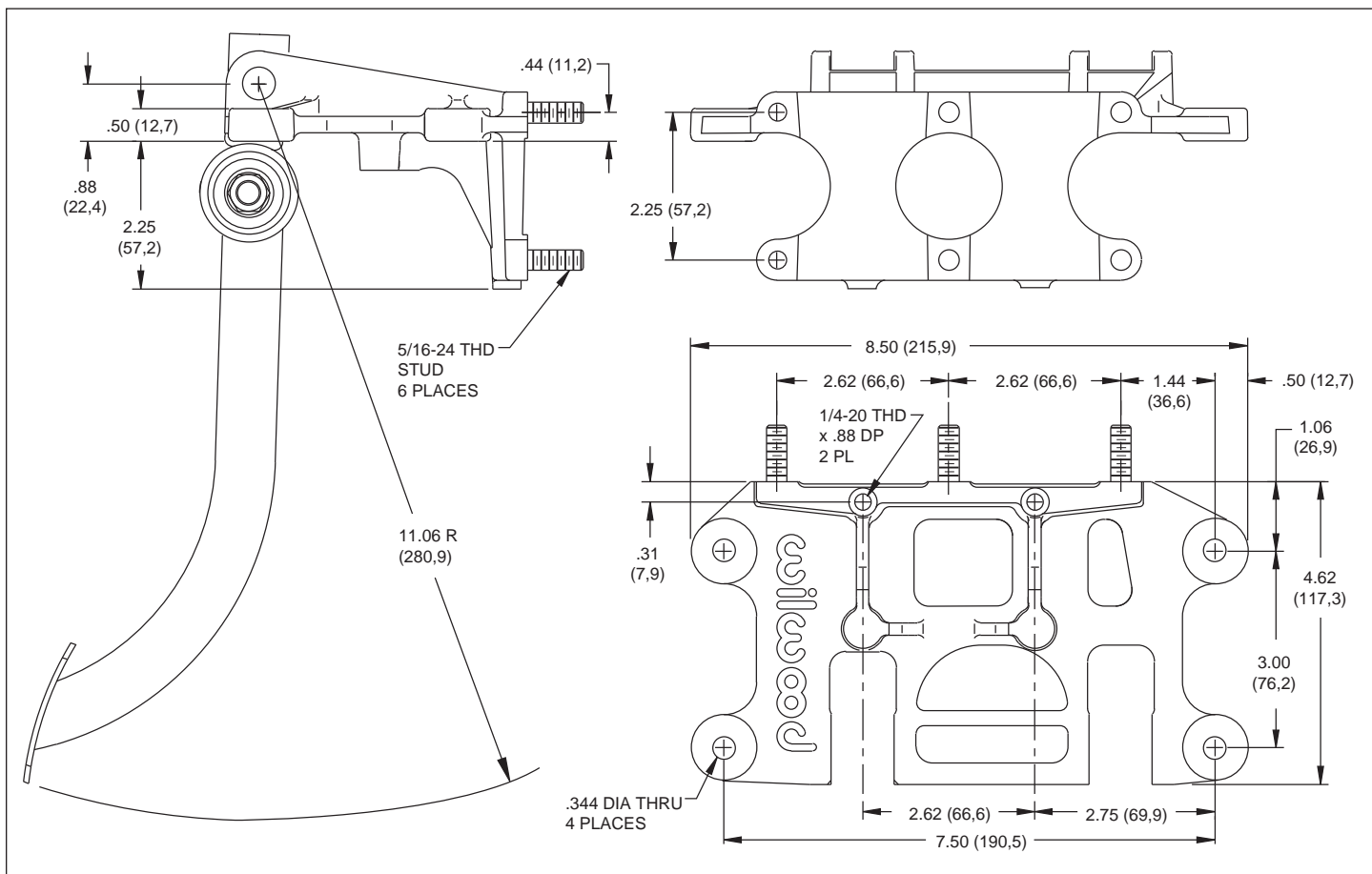

Forward Mount Dual Steel Pedal Assembly, Physical Dimensions, 6.25:1 Ratio (P/N 340-6916)

Additional Information and Recommendations

- The pedal assembly uses standard racing master cylinder mounting patterns. Wilwood's remote, high volume aluminum and composite master cylinder's mount directly to the pedal assembly, as do most other high performance master cylinders. All master cylinder mounting hardware is included with the pedal assembly. Master cylinder flange should mount flush to pedal assembly and be held in place with enclosed washers and locknuts. The clevis on each pedal has a 5/16-24 thread. Make sure to use a jamnut on the master cylinder pushrod when threaded into clevis and check that pushrod is allowed to fully retract when pedal is released.
- Wilwood EXP 600 Racing Brake Fluid (P/N 290-6209) or other DOT 3 fluid is recommended for race cars and high performance vehicles where brake temperatures exceed normal operating conditions. **NOTE: Silicone DOT 5 brake fluid is NOT recommended for racing or performance driving.**
- Adjust the balance bar so that the appropriate front to rear brake balance is achieved.
- If after following the instructions, you still have difficulty in assembling your Wilwood forward mount dual pedal assembly, consult your local chassis builder, or retailer where the component was purchased for further assistance.

Brake Testing and Pad Bedding

**WARNING • DO NOT DRIVE ON UNTESTED BRAKES
BRAKES MUST BE TESTED AFTER INSTALLATION OR MAINTENANCE
MINIMUM TEST PROCEDURE**

- Make sure pedal is firm: Hold firm pressure on pedal for several minutes, it should remain in position without sinking. If pedal sinks toward floor, check system for fluid leaks. DO NOT drive vehicle if pedal does not stay firm or can be pushed to the floor with normal pressure.
- At very low speed (2-5 mph) apply brakes hard several times while turning steering from full left to full right, repeat several times. Remove the wheels and check that components are not touching, rubbing, or leaking.
- Carefully examine all brake components, brake lines, and fittings for leaks and interference.
- Make sure there is no interference with wheels or suspension components.
- Drive vehicle at low speed (15-20 mph) making moderate and hard stops. Brakes should feel normal and positive. Again check for leaks and interference.
- Always test vehicle in a safe place where there is no danger to (or from) other people or vehicles.
- Always wear seat belts and make use of all safety equipment.

PAD BEDDING PROCEDURE:

- Pump brakes at low speed to assure proper operation. On the race track, or other safe location, make a series of hard stops until some brake fade is experienced. Allow brakes to cool while driving at moderate speed to avoid use of the brakes. This process will properly burnish the brake pads, offering maximum performance.