



# CORVETTE C-4 SUPERLITE 6R BIG BRAKE FRONT HAT KIT

## Models Covered:

Chevrolet Corvette C-4

1988-1996

## Kit Features:

- Choice of 13.00" SRP or GT series rotors.
- Upgrade from OE brakes for street performance and track day events.
- Choice of black or red forged billet Superlite 6R calipers.
- Full bolt-on installation compatible with ABS and OE master cylinder output.
- Additional wheel clearance required.

## Component Features:

### Forged Billet Superlite 6R Radial Mount Calipers

- Fully machined billet forgings, based on a race proven radial mount design, demonstrate superior strength and resistance to deflection under high loads.
- High clamping force and balanced pad loading is delivered from 6 stainless steel pistons that reduce heat transfer and resist corrosion.
- Spring loaded stainless steel "SRS" bridge plates reduce noise by dampening engagement harmonics and stopping pad rattle. Bridge wear caused by gouging at the pad trailing edge is also eliminated.
- Center bridge bolt design adds additional strength against caliper separation under load while allowing easy access for pad service without caliper removal.
- Available with the standard high luster black anodizing or special order with a brake fluid and temperature resistant bright red coating.

### Directional Vane 13.00" Rotors

- Directional 48 vane rotors demonstrate increased cooling efficiency over non-directional OE rotors through increased surface area and air circulation between the rotor faces.
- SRP series rotors are drilled and slotted for enhanced pad performance through improved pad cleaning, heat venting, and gas dispersion during braking. The directional drill and slot pattern is complimented with a corrosion resistant silver zinc finish to provide an aggressive high tech / custom appearance inside the wheels.
- GT series rotors are competition prepared with asymmetrical face slotting, full detail machining, and individual dynamic balancing to deliver the highest degree of durability and thermal stability in sustained high temperature conditions and smooth operation at all speeds.
- 13.00" rotors provide performance upgrade options with increased brake leverage over the factory 12.00" rotors.

### Forged Aluminum GT Rotor Mounting Hats

- GT forged aluminum rotor hats are lightweight to reduce power robbing rotating weight and strong to handle the exceptional brake torque generated by the SL6R calipers.
- Hats are black anodized to resist corrosion and add to the aggressive competition look inside the wheel.

### Wilwood High Performance Brake Pads

- SRP rotor kits include PolyMatrix "Q" compound pads. "Q" delivers improved friction and temperature range over OE compounds with the lowest noise and dust levels available from a high performance pad.
- GT rotor kits include BP-10 compound "Smart Pads". BP-10 provides middle to upper temperature range friction and fade resistance found in metallic based race compounds, but with the low temperature response, low dust, and quiet engagement of a street compound pad.

### Mounting Hardware and Plumbing

- Race proven radial mount system includes brackets, high strength fasteners, washers, and alignment shims for an accurate and secure installation.
- Optional stainless steel braided competition flex line kits with machine crimped ends include the fittings necessary to connect the calipers with the OE brake line fitting at the chassis. Flex line kits must be ordered separately.

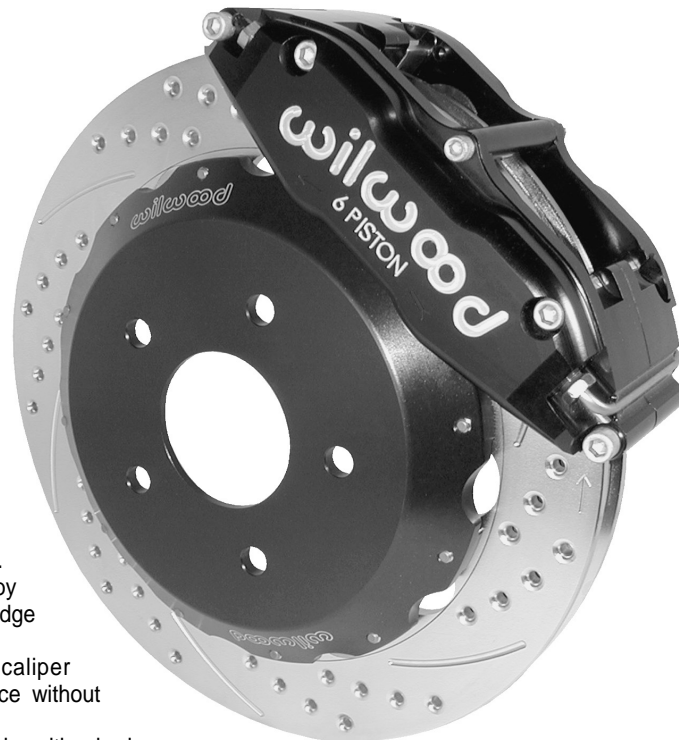

Corvette C-4 Big Brake Front Kit with SRP Rotor

Please check the diagram on the back of this page for minimum inside wheel clearance requirements

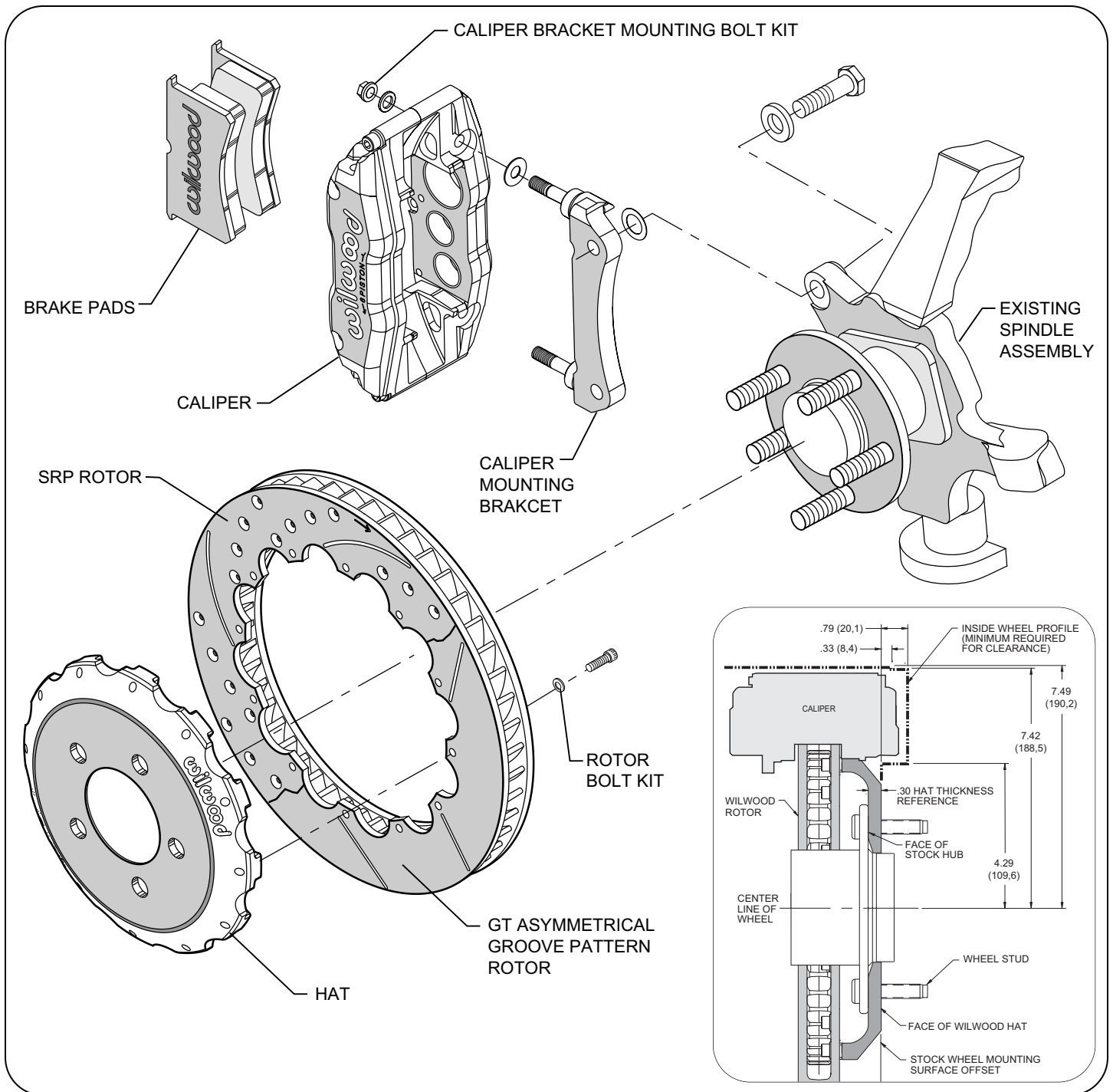

Typical Installation Diagram, Major Components Identified. Minimum Wheel Fit Dimensions Shown Inset

**ORDERING INFORMATION: BRAKE AND FLEX LINE KITS:**

<u>MAKE / MODEL</u>	<u>YEAR</u>	<u>GT ROTOR KIT</u>	<u>KIT PART NUMBERS</u> <u>SRP ROTOR KIT</u>	<u>FLEX LINE KITS</u>
Corvette C-4	1988-1996	140-8337	140-8337-D	220-8338

**ORDERING INFORMATION, USER SERVICEABLE COMPONENTS:**

<u>PART NUMBER</u>	<u>CALIPER</u>	<u>GT ROTOR-R/L</u>	<u>SRP ROTOR-R/L</u>	<u>AXLE SET PADS</u>	<u>HAT</u>	<u>ROTOR BOLT KIT</u>	<u>BRACKET KIT (EA)</u>
140-8337	120-8079/80-RS	160-6833/34	—	150-8855K	170-6837	230-4572	250-8519
140-8337-D	120-8079/80-RS	—	160-6835/36	15Q-6828K	170-6837	230-4572	250-8519