

2005 - PRESENT MUSTANG • DYNALITE PRO SERIES REAR PARKING BRAKE KIT

Models Covered:

Ford Mustang

2005 - 2006

Kit Features:

- Billet forged 4-piston Dynalite calipers
- Full bolt-on installation for vehicles originally equipped with rear discs brakes
- Retains use of factory park brake assembly
- Compatible with ABS and OE master cylinder output
- Designed for use on Mustang 8.8, 5 lug applications (See clearance diagram on the back of this page to be sure the wheels that will be utilized will fit properly)

Component Features:

Forged Billet Dynalite Four Piston Calipers

- High strength FEA designed stress-flow forged billet bodies provided highest clamping efficiency and lowest deflection of any caliper in its class.
- Four stainless steel pistons generate high clamping force and balanced pad loading with low heat transfer and high resistance to corrosion.
- Spring loaded stainless steel SRS bridge plates reduce noise by damping engagement harmonics and stopping pad rattle. Bridge wear caused by gouging at the pad trailing edge is also eliminated.
- Internal fluid passages prevent all potential problems associated with external fluid transfer tubes.
- Four corner bleed screws accommodate effective gas evacuation regardless of mounting position.
- Top loaded pads are easily inspected and serviced without the need for caliper removal from the mount.

SRP or HP Series 12.19" Diameter Rotors

- Increased diameter multiplies stopping leverage over OE diameter rotors.
- 32 vane vented iron design provides high cooling efficiency.
- SRP Series rotors are e-coated to resist corrosion and feature an engineered directional drill and slot pattern for an aggressive high tech appearance inside the wheel. The holes and slots enhance pad performance by reducing pad glazing and dispersing the gasses and some of heat generated during braking.
- HP series full surface rotors are precision machined at less than .001" for total parallelism, flatness, and run-out. This non-drilled version carries additional mass for increased thermal stability in sustained heat competition.

Wilwood BP-10 "Smart Pads"

- BP-10 compound "Smart Pads" are a remarkable new metallic composite formula that combines the quiet, low dust operation of a high performance street pad with the increased friction and higher fade resistance of a medium range, racing compound.

Mounting Hardware and Plumbing

- The caliper mounting bracket is incorporated into the rear drum shoe assembly which assures a precise fit and caliper alignment. Premium grade studs, nuts, bolts, washers, and alignment shims are included.
- Stainless steel reinforced flex-line kits, with machine crimped ends, can be ordered separately to complete the installation and add to the custom detail of the suspension. "AN" style flex-lines provide improved pedal feel with quicker system response by minimizing the compliance or "swell" that can occur with OE rubber lines.



**Mustang Pro Series Rear
Kit with SRP Rotor**

Please check the diagram on the back of this page for minimum inside wheel clearance requirements

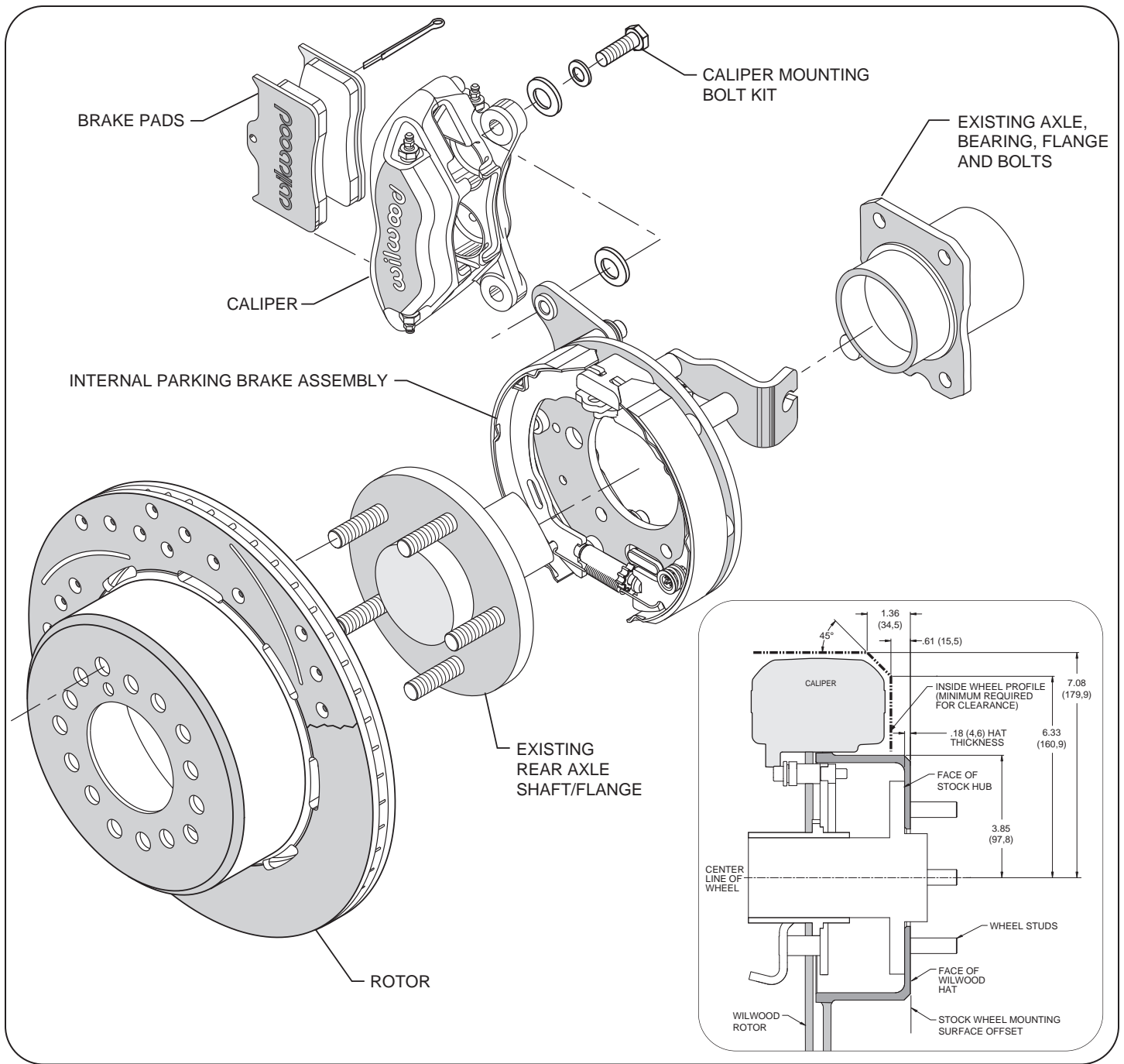

Typical Installation Diagram, Major Components Identified. Minimum Wheel Fit Dimensions Shown Inset

ORDERING INFORMATION: BRAKE AND FLEX LINE KITS:

MAKE / MODEL	YEAR	KIT PART NUMBERS			FLEX LINE KITS
		HP ROTOR KIT	SRP ROTOR KIT		
Ford Mustang 8.8	2005-2006	140-9228	140-9228-D	220-9248	

ORDERING INFORMATION, COMPONENTS AND SERVICE PARTS:

KIT NUMBER	CALIPER	HP ROTOR-R/L	SRP ROTOR-R/L	PAD AXLE SET	BRACKET KIT
140-9228	120-6806	160-6865	—	150-8850K	249-9226/27
140-9228-D	120-6806	—	160-6970/71	150-8850K	249-9226/27