



W6AR FRONT BIG BRAKE KITS 2010 CAMARO

Models Covered:

Chevrolet Camaro

2010 Model Year

Kit Features:

- Extreme performance upgrade for aggressive street / track combination vehicles and dedicated competition machines.
- Engineered to maximize braking capacity inside custom and race offset wheels.
- Simple bolt-on installation with no modifications required.
- Fully compatible with ABS and OE master cylinder output.

Component Features:

W6AR Forged Billet Radial Mount Calipers

- Competition proven and fully detail machined forged billet body demonstrates superior strength and resistance to deflection and separation under high load.
- Differential bore six piston design generates big brake clamping force with balanced pad loading for even wear in all sustained high heat, high load conditions.
- W6AR calipers use stainless pistons to resist corrosion and reduce heat transfer from the pads.
- Spring loaded SRS bridge plates dampen noise and engagement harmonics while protecting the caliper bridge from wear by pad gouging.
- High temperature, fluid resistant high gloss black finish is standard, with red available as an order option.

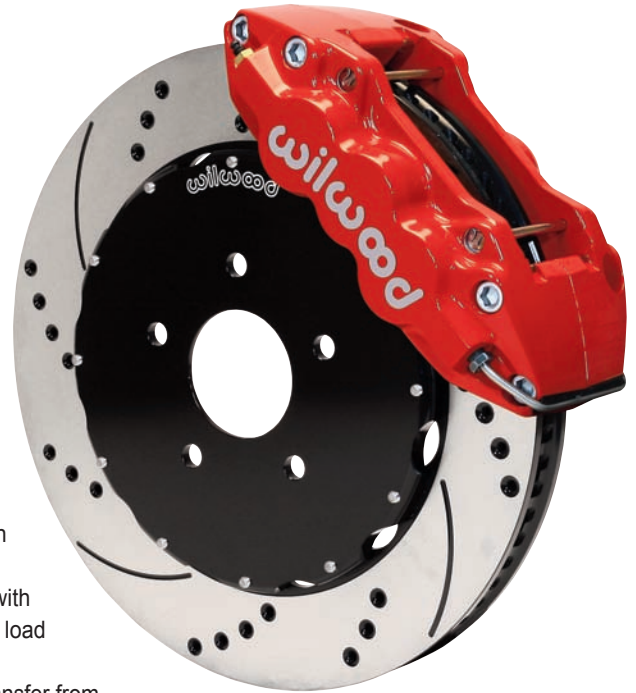

**Camaro Big Brake Front Kit with
SRP Rotor and Red Caliper**

SRP Directional Vane 14.25" Rotors

- SRP directional drilled and slotted rotors enhance pad performance with consistent response by cleaning and venting gasses, dust, and burnt pad material. A proprietary black e-coat finish is applied to resist corrosion.
- SRP rotors are close tolerance machined to less than .001" for total flatness, parallelism and run-out to assure true running at all speeds.
- Big 14.25" diameter provides increased leverage for improved stopping power over all OE sizes.

Forged Aluminum GT Mounting Hats

- Forged aluminum rotor mount hats help reduce weight with the strength to handle the exceptional brake torque delivered by the W6AR caliper.
- Black anodized finish resists corrosion while adding to the aggressive competition look inside the wheel.

Wilwood BP-10 "Smart Pads"

- All kits include BP-10 metallic-composite compound "Smart Pads". BP-10 delivers the increased friction; higher fade resistance, and longer wear of an entry-level track pad, with virtually noise and dust free performance for the street.
- Optional race-only compounds can be ordered to suit the braking requirements at all levels of severe duty and sustained high heat competition.

Radial Mounting Hardware and Plumbing

- Radial mounting provides secure attachment directly to the OE mount with two planes of adjustment for precise alignment over the rotor. Brackets, premium grade fasteners, and alignment shims are included in each kit.
- Stainless steel braided competition flex line kits, with machine crimped ends and the fittings necessary to connect the calipers with the OE chassis bulkhead, are available and must be ordered separately.

NOTE
SPECIFIC PARTS MAY VARY FROM DIAGRAM

WARNING
INSTALLATION OF THIS KIT SHOULD ONLY BE PERFORMED BY PERSONS EXPERIENCED IN THE INSTALLATION AND PROPER OPERATION OF DISC BRAKE SYSTEMS.

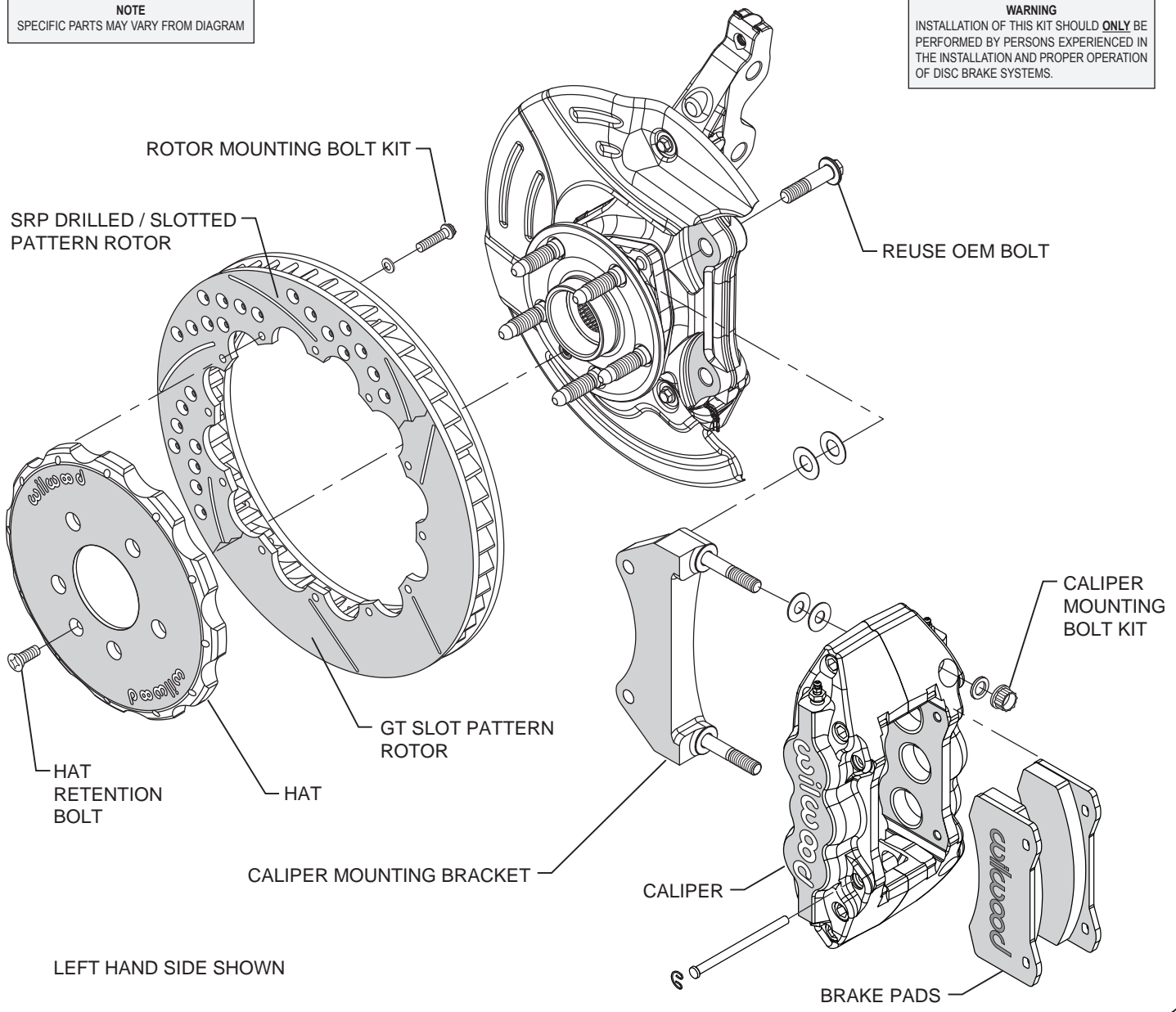

Typical Installation Diagram

ORDERING INFORMATION:

PART NUMBER	DESCRIPTION	RACER
140-11269	KIT, FRONT, CAMARO, 2010, W6A 14.25 ROTOR	\$2,398.42
140-11269-D	KIT, FRONT, CAMARO, 2010, W6A 14.25 ROTOR, DRILLED	\$2,511.54
140-11269-DR	KIT, FRONT, CAMARO, 2010, W6A 14.25 ROTOR, DRILLED, RED	\$2,511.54
140-11269-R	KIT, FRONT, CAMARO, 2010, W6A 14.25 ROTOR, RED	\$2,398.42