



# KART / JR. DRAGSTER CALIPER

## Caliper Highlights:

Wilwood's **Kart / Jr. Dragster Caliper** has been designed specifically for racing. A unique self retracting and adjusting piston system has been incorporated into this caliper which enables the piston to retract as the brake line pressure is reduced. The caliper can be mounted on either side of the vehicle and comes in three rotor widths to accommodate most applications. Weighing a meager 1.2 pounds, the caliper's lightweight billet design includes high performance, high friction brake pads. Additional features include deep cup stainless steel piston for reduced heat transfer, cotter pin, pad retainer, internal fluid passage and blue anodized finish. A specifically designed master cylinder is also available for use with this caliper.



## ORDERING INFORMATION:

BORE SIZE		DISC WIDTH		PART NUMBER
1.00"	25,4 mm	.12"	3,0 mm	120-5498
1.00"	25,4 mm	.18"	4,6 mm	120-5750
1.00"	25,4 mm	.50"	12,7 mm	120-5499

## KART / JR. DRAGSTER CALIPER, MOUNTING DIMENSIONS:

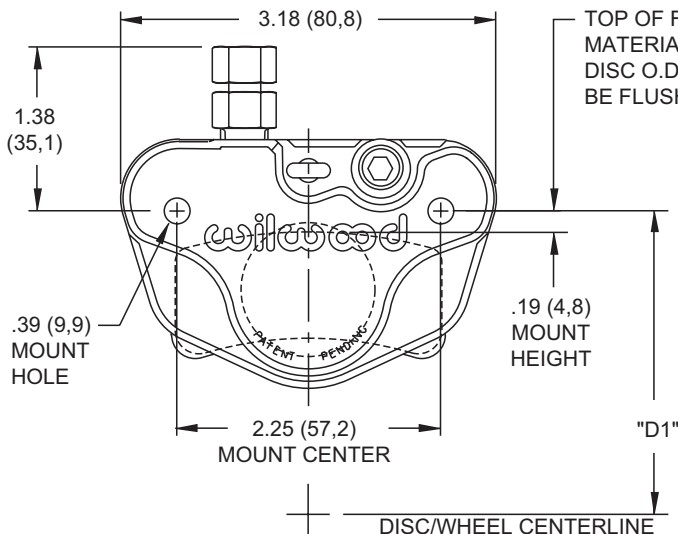

DIMENSION "D1" =  
(DISC DIAMETER/2) + .19 (4,8)

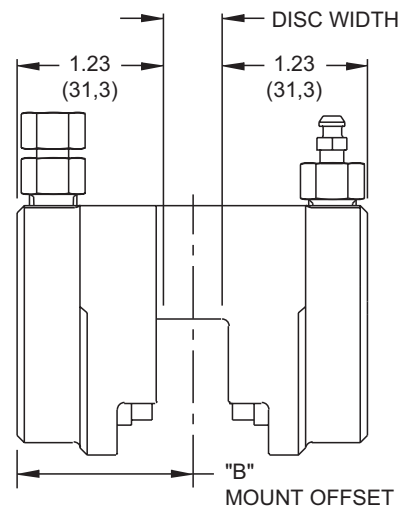

DISC WIDTH	"B" MOUNT OFFSET	DISC DIAMETER
.12 (3,05)	1.32 (33,5)	8.00 (203,2)
.18 (4,6)	1.36 (34,5)	8.00 (203,2)
.50 (12,7)	1.51 (38,4)	8.75 (222,3)

## ORDERING INFORMATION: USER SERVICEABLE COMPONENTS:

ASSEMBLY	INBOARD BODY	OUTBOARD BODY	PISTON	BRAKE PAD KIT (2 PACK)	REBUILD KIT*
120-5498	110-5477	110-5478	200-5474 (1.00")	150-5602K	220-5766
120-5499	110-5477	110-5497	200-5474 (1.00")	150-5602K	220-5766
120-5750	110-5477	110-5749	200-5474 (1.00")	150-5602K	220-5766

\*INCLUDES FITTINGS, RUBBER COMPONENTS AND PAD RETAINERS