

# Wilwood Disc Brake Installation

## Front Big Brake Installation on a 2011 Honda CR-Z Hybrid



Honda has introduced the first six speed production hybrid. With its short wheelbase and responsive handling, this is a car that begs to be driven on roads with lots of corners and switchbacks. As these vehicles hit the road and become popular performance vehicles, one thing that needs to be upgraded will be the brakes. Especially when driving on those curvy roads when the brakes will get a workout. This becomes evident when one realizes that more cars are passed under braking than anywhere else on the track. **Wilwood Disc Brakes** has the solution! You need Wilwood's if you want to stop your CR-Z in road race like conditions.

Wilwood is offering performance braking solutions for the first generation CR-Z (our test fit vehicle was a 2011 model year). The base kit (P/N 140-11978) features Wilwood's Superlite 6 piston differential bore radial mount calipers clamping down on oversized 12.88" diameter GT slot pattern vented rotors. The kit comes with aluminum hats, mounting brackets, and all hardware for an easy bolt-on installation. BP-10 high performance street pads round out the kit. Other brake pad compounds for off-road applications are an available option. Optional items include SRP drilled and slotted rotors, and/or red powder coated calipers.

As you read through the installation procedure you will see that it is basically a bolt-on kit, just as Wilwood advertises, with only having to drill a hole in the brake line bracket. Kits includes everything necessary for an easy and complete installation. However, the stainless steel braided flexline kit, P/N 220-12016 is a necessary item and must be ordered



Wilwood part number 140-11978 comes complete with Superlite 6R calipers, caliper mounting brackets, GT rotors, aluminum hats, BP-10 brake pads and all necessary hardware for an easy bolt-on installation.

separately. You will be amazed as to how much better the Wilwood brake kit performs over the original factory brakes.

A complete set of mechanics tools including torque wrenches will be necessary. Also, a bottle of red *Loctite*® 271, PTFE thread tape, and Wilwood's Hi-Temp 570 racing brake fluid or Wilwood EXP 600 Plus Hi-Temp racing brake fluid for extreme temperature applications.

Before you begin the installation, read over the instructions carefully to be sure you understand the procedure, and make note of any additional steps that may have to be performed by a qualified machine shop. Compare the parts with the parts list on the installation document that came with the kit to ensure all necessary components are included.

**NOTE:** *Disc brakes should only be installed by someone knowledgeable and competent in the functioning and maintenance of disc brakes. If you are not sure, get help or return the product. You may obtain additional information and technical support by calling Wilwood at 805 • 388-1188, e-mail for technical assistance at: [support@wilwood.com](mailto:support@wilwood.com), or visit our web site at [www.wilwood.com](http://www.wilwood.com).*



**Sequence 1:** Raise the front wheels off the ground and support the front suspension according to the vehicle's manufacturer's instructions. Remove the lug nuts, then slide off the wheel.

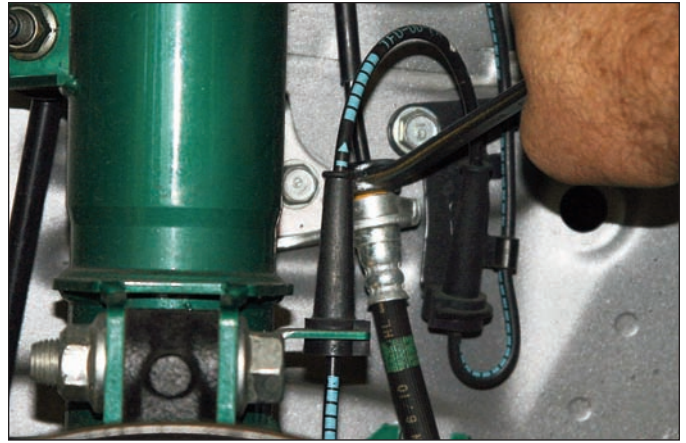

**Sequence 4:** Disconnect the rubber hose where it connects to the brake hard line. Try to keep fluid leakage to a minimum.



**Sequence 2:** Break loose the hat locator screws using an impact screw driver. Then remove the screws.

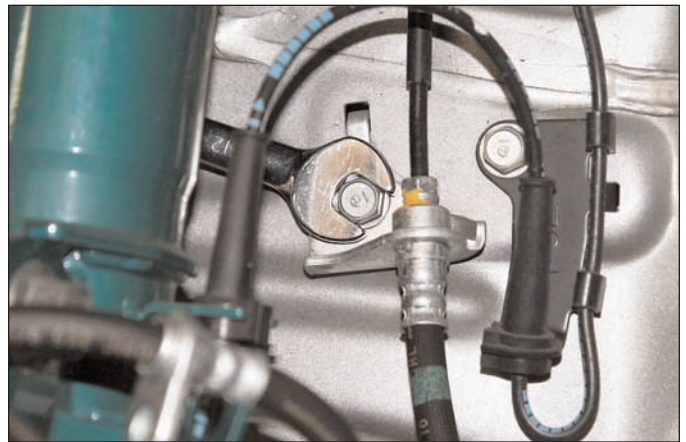

**Sequence 5:** Remove the hose bracket that secured the rubber/hard line junction from the inside of the wheel well.



**Sequence 3:** Loosen and remove the bolt securing the hose bracket to the shock support and lift the hose and bracket out of the way.

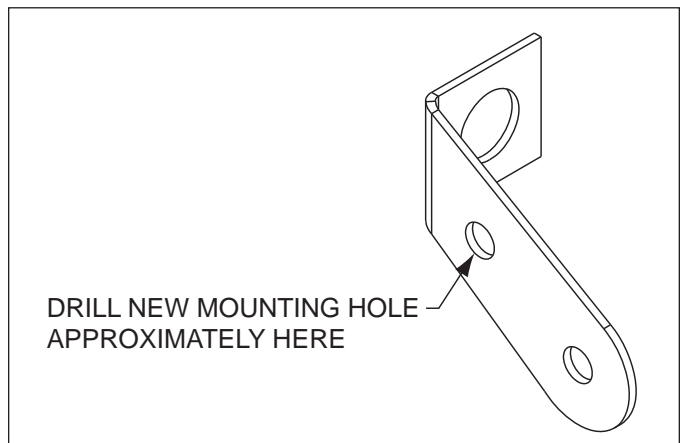

**Sequence 6:** Attached the new Wilwood flexline kit P/N 220-12016 to the hard line and secure with new bracket (P/N 250-9349/50). Position bracket so that the hard line has no kinks, drill a hole approximately as shown (arrow) and attach to wheel well using OE bolt.





**Sequence 7:** Using a breaker bar and socket, break loose the caliper mounting bolts from the back side.



**Sequence 10:** Remove the screws that secure the dust shield in place.

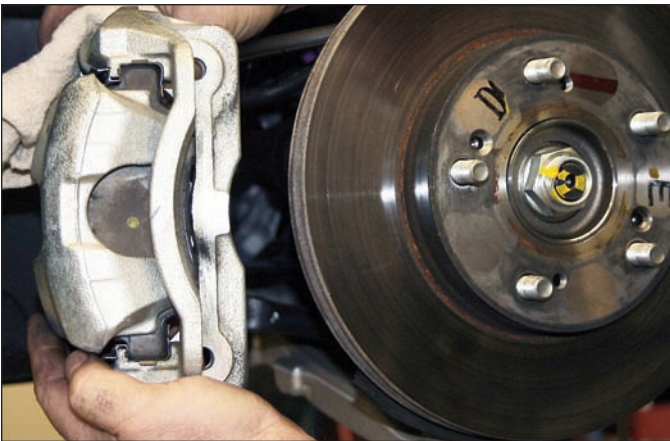

**Sequence 8:** Lift off and remove the caliper. Remember there is still some fluid in the rubber hose attached to the caliper.



**Sequence 11:** Using a pair of tin shears, cut the dust shield at its two smallest diameter locations and pull apart. Remove and discard dust shield.



**Sequence 9:** Slide off the rotor from the hub. If it is stuck, it may be necessary to hit it a few times with a rubber mallet to break loose.



**Sequence 12:** Install the caliper mounting bracket bolt and washer from the outboard side of the caliper mounting ears.





**Sequence 13:** Initially place one .015" thick shim, and one .033" thick shim between the mounting ear and the caliper mounting bracket.

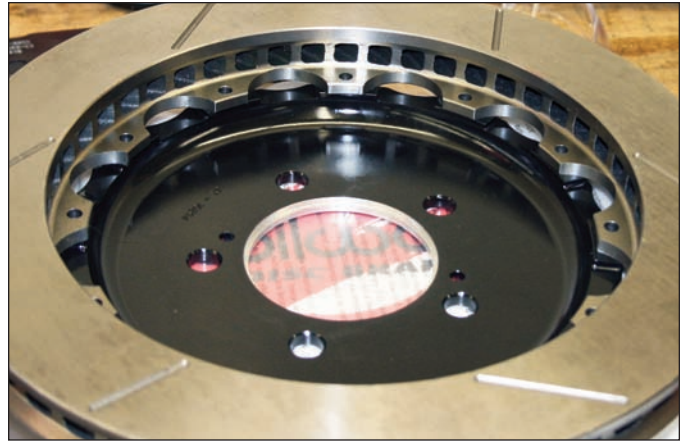

**Sequence 16:** The hat needs to be bolted to the rotor. Orient the rotor over the hat in the configuration shown above.

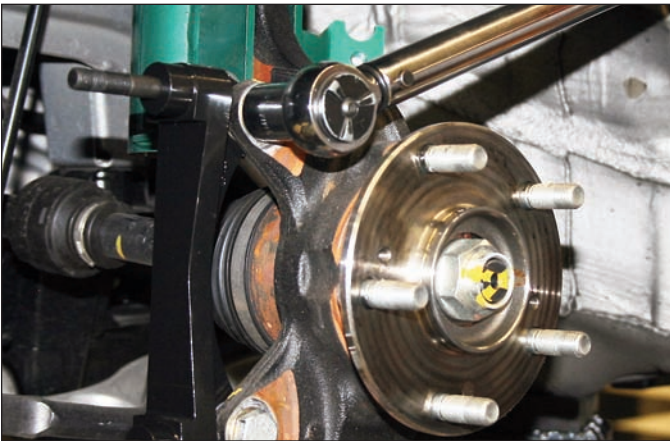

**Sequence 14:** Attach the Wilwood caliper mounting bracket to the OEM mounting ears from the back side. Temporarily tighten the mounting bolts. **NOTE:** The bracket must fit squarely against the mounting ears. Inspect for interference from casting irregularities, burrs, etc. Grind as necessary. Do not Loctite at this time.



**Sequence 17:** Place one flat washer over each hole on the rotor mounting tabs. Coat the mounting bolts with red Loctite® 271 and slide through the washer and thread into the hat. Using an alternating sequence, torque bolts to 155 in-lbs.



**Sequence 15:** Install the rotor registration adapter onto the axle register against the hub face with the larger O.D. facing inward toward the hub face.

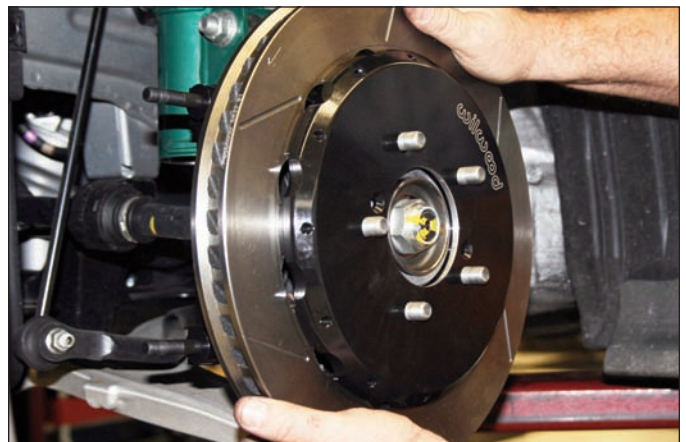

**Sequence 18:** Install the hat/rotor assembly over the studs on the hub assembly. **NOTE:** The hat/rotor must fit flush against the axle hub flange or excessive rotor run out may result.



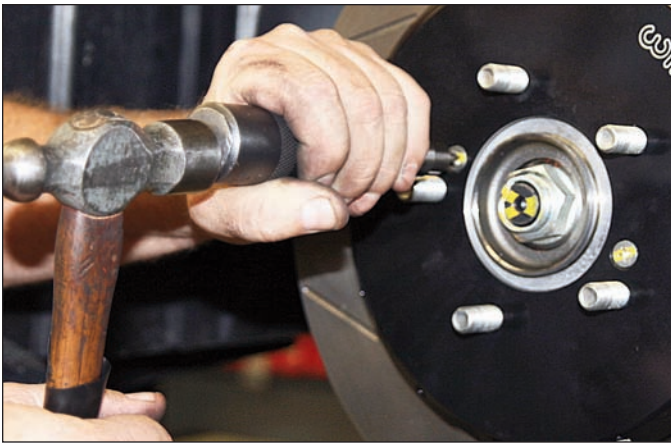

**Sequence 19:** Reinstall the hat locator screws using an impact screw driver to keep the hat/rotor in place while continuing with the rest of the installation.

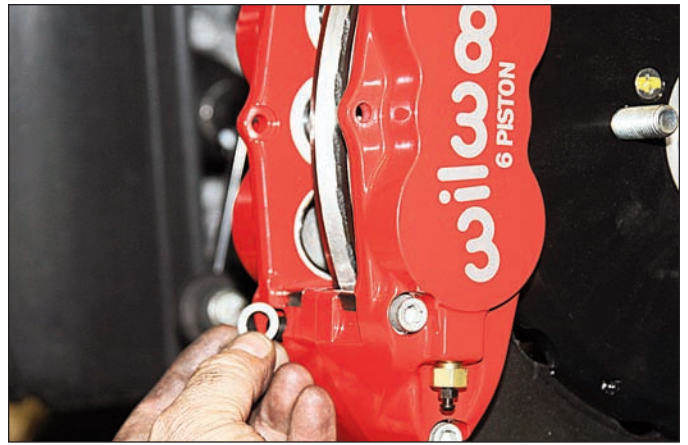

**Sequence 22:** This kit includes distinct right and left hand calipers. Mount the caliper onto the bracket so that the largest pistons are at the rotor exit end of the caliper, in relation to the direction of rotor rotation. Left hand installation shown.

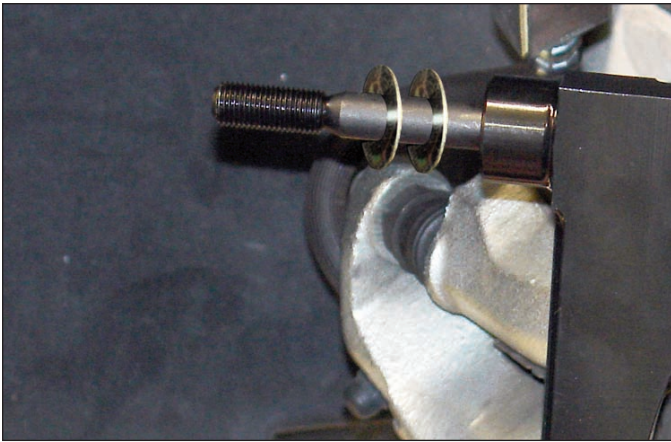

**Sequence 20:** Lubricate the caliper mounting studs with lightweight oil. Initially place two shim washers on each stud between the bracket and caliper.

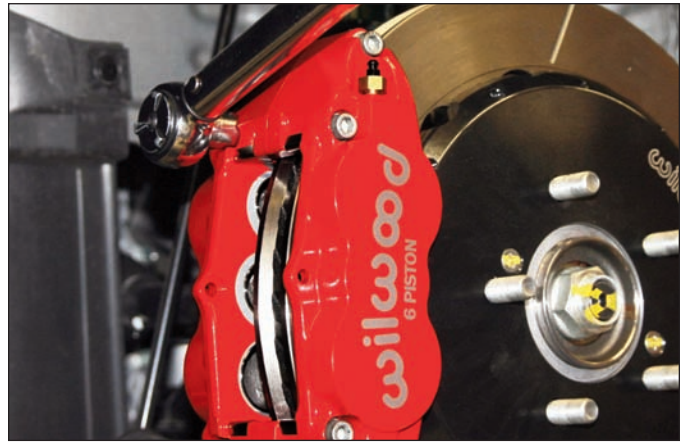

**Sequence 23:** Secure the caliper with washer and locknut, temporarily tighten. View the rotor through the top opening of the caliper. The rotor should be centered in the caliper. If not, adjust by adding or subtracting shims between the bracket and the mounting ears. Once the caliper alignment is correct, remove the bracket bolts one at a time and apply red *Loctite*® 271 to the threads and torque to 65 ft-lb.



**Sequence 21:** Remove the protective sticker from the caliper fluid inlet. Coat the inlet fitting with PTFE thread tape and screw into the caliper with the 90° angle perpendicular to the length of the caliper.

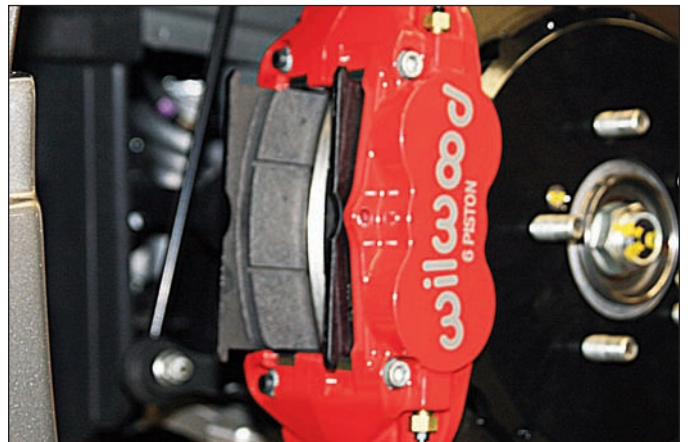

**Sequence 24:** Having already removed the caliper center bridge pad retainer bolt, nut, and tube from the caliper, insert the brake pads into the caliper with the friction material facing the rotor.



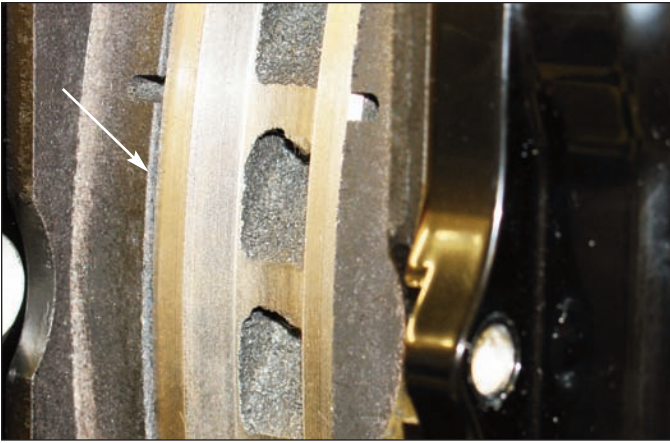

**Sequence 25:** Check that the top of the brake pad is flush with the outside diameter of the rotor (arrow). If not, adjust by adding or subtracting shims between the bracket and the caliper.



**Sequence 28:** Connect the other end of the flexline to the fitting installed in the caliper. Secure line as necessary to prevent contact with moving suspension, brake, or wheel components. Bleed the system referring to the additional information in the data sheet as necessary for proper bleeding instructions.

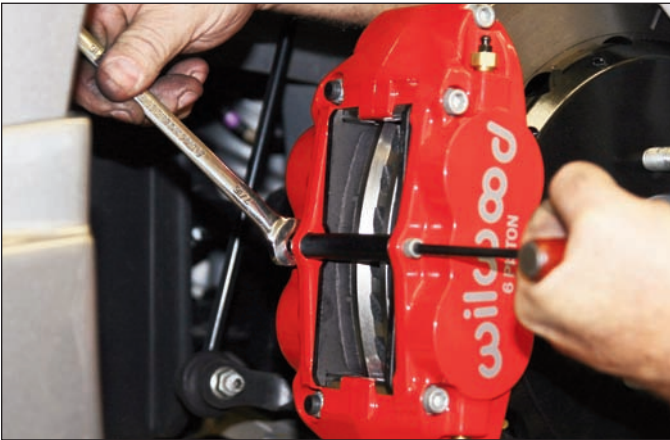

**Sequence 26:** After the pad height is set, install the center bridge pad retainer tub, bolt, and lock nut using an Allen wrench and open-end wrench. The lock nut should be snug without play in the bolt or tube. Be cautious not to over tighten. Then finalize the caliper mounting by torquing the caliper mounting lock nuts to 35 ft-lb.



**Sequence 29:** Install the wheel and torque the lug nuts to manufacturer's specification. Bed in the brake pads and rotor in a safe location before general use driving.



**Sequence 27:** Slice a grommet so that it can be slid over the Wilwood flexline that is already attached to the hard line. Install into the OE bracket and attach bracket using OE bolt in original location.

## Brake Testing

**WARNING • DO NOT DRIVE ON UNTESTED BRAKES  
BRAKES MUST BE TESTED AFTER INSTALLATION OR MAINTENANCE  
MINIMUM TEST PROCEDURE**

- Make sure pedal is firm: Hold firm pressure on pedal for several minutes, it should remain in position without sinking. If pedal sinks toward floor, check system for fluid leaks. DO NOT drive vehicle if pedal does not stay firm or can be pushed to the floor with normal pressure.
- At very low speed (2-5 mph) apply brakes hard several times while turning steering from full left to full right, repeat several times. Remove the wheels and check that components are not touching, rubbing, or leaking.
- Carefully examine all brake components, brake lines, and fittings for leaks and interference.
- Make sure there is no interference with wheels or suspension components.
- Drive vehicle at low speed (15-20 mph) making moderate and hard stops. Brakes should feel normal and positive. Again check for leaks and interference.
- Always test vehicle in a safe place where there is no danger to (or from) other people or vehicles.
- Always wear seat belts and make use of all safety equipment.

### **Wilwood Disc Brakes**

4700 Calle Bolero, Camarillo, CA 93012

805 / 388-1188 • [www.wilwood.com](http://www.wilwood.com)

Copyright © 2012 Wilwood Disc Brakes

All Rights Reserved