

# SUPERLITE 6R FRONT BIG BRAKE KITS

## 1959-64 CHEVROLET IMPALA • 1963-64 CORVETTE

### Kit Highlights:

- Fully bolt-on big brake upgrades for use with the OE drum brake spindles on all 1959-64 Impala, BelAir, Biscayne, El Camino, and the 1963-64 Corvettes.
- Choice of 12.88" or 14.00" rotors to compliment wheel style.
- Standard kits available with red or black sealed gloss powder coat caliper finish.
- Optional "Quick-Silver" nickel plated, and other powder coat color calipers available by custom order.
- Full big brake styling and real big brake stopping power with top end performance for the street and track.

### Component Features:

#### Billet FNSL6R Radial Mount Calipers

- Super high-strength forged and machined billet alloy bodies deliver big brake stopping power and consistent performance with manual or power brake systems.
- Center bridge bolt design adds additional strength against caliper separation and deflection under high load while allowing easy access to the pads for service without caliper removal.
- Six-piston, progressive differential bore design delivers high clamping efficiency and balanced loading for consistent stopping and even pad wear.
- Low thermal conductivity and high corrosion resistance of stainless steel pistons provides lower caliper temperatures and longer, trouble free service life.
- Spring loaded SRS bridge plates dampen noise and protect the caliper bridges from wear at the pad trailing edge.

#### GT Competition or SRP Performance Directional Vane 12.88" or 14.00" Rotors

- Directional vane rotors provide the highest degree of cooling efficiency thru increased cooling surface area and improved air circulation.
- GT Series 12.88" carbon iron GT-48 and the 14.00" Spec 37 alloy SV-GT rotors are competition prepared with full detail precision machining, asymmetrical face slotting for pad cleaning, and individual dynamic balancing for smooth operation at all speeds. GT series rotors deliver maximum precision, durability, and thermal stability for sustained high heat competition.
- SRP Series rotors combine our signature drill and slot pattern with a durable black E-coat finish to deliver durable high tech styling with the added strength and cooling capacity of the directional vane cores. SRP rotors deliver long service life on the street, with the durability to withstand those occasional fun days at the track.

#### Forged Aluminum Hubs and Hats

- Forged and fully machined billet hubs, with 1/2-20 grade 8 wheel studs mount to the OE spindle using tapered roller bearings and races.
- Forged GT series competition style hats are face mounted and bolt secured to provide ultimate mounting strength for big brake torque from the 12.88" and 14.00" rotors.

#### Wilwood "Smart Pads"

- Each kit includes BP-10 compound "Smart Pads". BP-10 is a unique metallic composite compound that delivers quiet, low dust performance, but with the improve response, friction, and temperature range of a semi-metallic style pad.
- Optional track day and competition only pad compounds are also available to fine tune brake response for a particular vehicle type, individual driving style, or preferences.

#### Brackets, Hardware, and Plumbing

- Brackets and premium grade hardware to mount the radial mount BNSL6R calipers to the OE spindle are included with each kit.
- DOT approved flexline kits, required to adapt Wilwood calipers to your chassis plumbing, are available separately by vehicle model.



**Big Brake Front Kit with SRP Rotor and Red Caliper**  
Download High Resolution Photo,  
[click here](#)

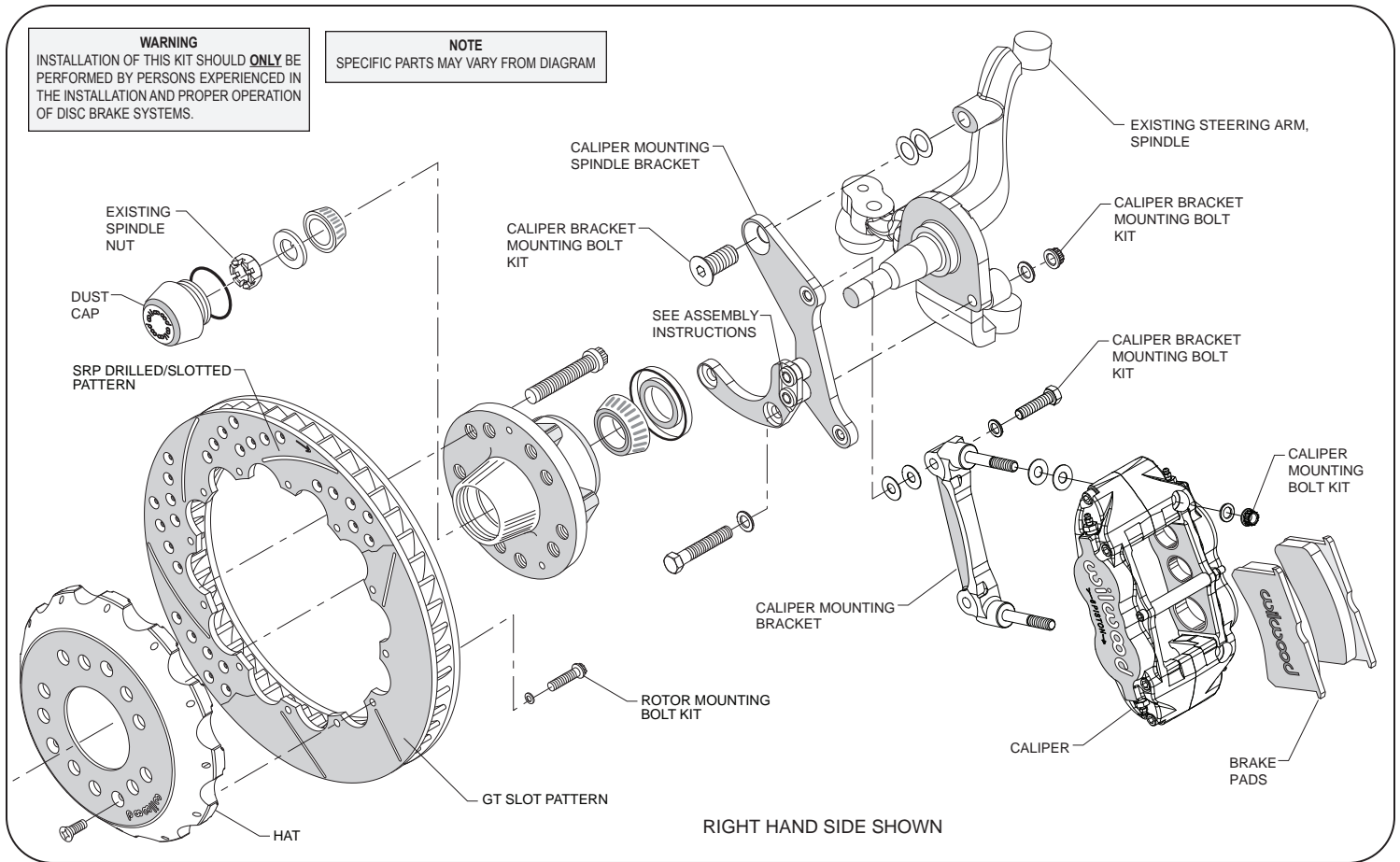

**Typical Installation Diagram (12.88" Rotor Diameter Kit Shown)**

**ORDERING INFORMATION: 1959-64 CHEVY FULL SIZE PASSENGER VEHICLE, 1963-64 CORVETTE**

<u>KIT NUMBER</u>	<u>CALIPER (1)</u>	<u>ROTOR</u>	<u>PAD TYPE</u>	<u>FLEXLINE KIT</u>
140-12460	FNSL6R-Black	GT-48, 12.88"	7416	220-6856
140-12460-D	FNSL6R-Black	SRP, Drilled & Slotted, 12.88"	7416	220-6856
140-12460-DR	FNSL6R-Red	SRP, Drilled & Slotted, 12.88"	7416	220-6856
140-12460-R	FNSL6R-Red	GT-48, 12.88"	7416	220-6856
140-12465	FNSL6R-Black	SV-GT, Spec 37, 14.00"	7416	220-6856
140-12465-D	FNSL6R-Black	SRP, Drilled & Slotted, 14.00"	7416	220-6856
140-12465-DR	FNSL6R-Red	SRP, Drilled & Slotted, 14.00"	7416	220-6856
140-12465-R	FNSL6R-Red	SV-GT, Spec 37, 14.00"	7416	220-6856

NOTE: (1) For "Quick-Silver" nickel plated calipers, request calipers option 120-11780-N, 120-11781-N

**BRAKE PAD OPTION - TYPE 7416**

<u>PAD SET NO.</u>	<u>COMPOUND</u>	<u>USES</u>
150-8855K	BP-10	Low noise, low dust, high-performance street pad supplied with all kits
150-9415K	BP-20	Extended temperature street and track compound
15Q-6828K	PolyMatrix Q	Lowest noise and dust, enhanced ceramic formula
15E-6707K	PolyMatrix E	Entry level track day compound, slightly harsh for street use
15B-6705K	PolyMatrix B	Higher temperature race-only compound, medium-hard braking tracks
15H-8546K	PolyMatrix H	High temp, smooth engagement high friction, extreme competition use
15A-6709K	PolyMatrix A	High temp, aggressive high friction, extreme competition use