

INSTALLATION INSTRUCTIONS
FOR
REMOTE MASTER CYLINDER KIT

PART NUMBER(S)

260-3372, 260-3374, 260-3376
260-3378, 260-3380, 260-5920

**DISC BRAKES SHOULD ONLY BE INSTALLED BY SOMEONE
EXPERIENCED AND COMPETENT IN THE INSTALLATION AND
MAINTENANCE OF DISC BRAKES
READ ALL WARNINGS**

WARNING

IT IS THE RESPONSIBILITY OF THE PERSON INSTALLING ANY BRAKE COMPONENT OR KIT TO DETERMINE THE SUITABILITY OF THE COMPONENT OR KIT FOR THAT PARTICULAR APPLICATION. IF YOU ARE NOT SURE HOW TO SAFELY USE THIS BRAKE COMPONENT OR KIT, YOU SHOULD NOT INSTALL OR USE IT. DO NOT ASSUME ANYTHING. IMPROPERLY INSTALLED OR MAINTAINED BRAKES ARE DANGEROUS. IF YOU ARE NOT SURE, GET HELP OR RETURN THE PRODUCT. YOU MAY OBTAIN ADDITIONAL INFORMATION AND TECHNICAL SUPPORT BY CALLING WILWOOD AT (805) 388-1188, OR VISIT OUR WEB SITE AT WWW.WILWOOD.COM. USE OF WILWOOD TECHNICAL SUPPORT DOES NOT GUARANTEE PROPER INSTALLATION. **YOU**, OR THE PERSON WHO DOES THE INSTALLATION MUST KNOW HOW TO PROPERLY USE THIS PRODUCT. IT IS NOT POSSIBLE OVER THE PHONE TO UNDERSTAND OR FORESEE ALL THE ISSUES THAT MIGHT ARISE IN YOUR INSTALLATION.

RACING EQUIPMENT AND BRAKES MUST BE MAINTAINED AND SHOULD BE CHECKED REGULARLY FOR FATIGUE, DAMAGE, AND WEAR.



Need Additional Information?
Use Your SmartPhone and
Jump to Our Technical Tips
Section on Our Web Site.



WARNING

DO NOT OPERATE ANY VEHICLE ON UNTESTED BRAKES!
SEE MINIMUM TEST PROCEDURE WITHIN

ALWAYS UTILIZE SAFETY RESTRAINT SYSTEMS AND ALL OTHER AVAILABLE SAFETY EQUIPMENT WHILE OPERATING THE VEHICLE

IMPORTANT • READ THE DISCLAIMER OF WARRANTY INCLUDED IN THE KIT

NOTE: Some cleaners may stain or remove the finish on brake system components. Test the cleaner on a hidden portion of the component before general use.

Photographic Tip

Important and highly recommended: Take photos of brake system before disassembly and during the disassembly process. In the event, trouble-shooting photos can be life savers. Many vehicles have undocumented variations, photos will make it much simpler for Wilwood to assist you if you have a problem.

General Information and Installation Instructions

Installation of this kit should **ONLY** be performed by persons experienced in the installation and proper operation of disc brake systems. Before installing the Wilwood remote master cylinder kit, read the following instructions carefully to ensure a trouble-free installation.

Reservoir Selection:

The small or large reservoir will mount directly on the master cylinder body, or in a remote location using the remote mounting bracket (connected by the brake hose included with the kit). Use the large reservoir with two or more large displacement calipers, otherwise the small reservoir is adequate. Always use the clamps provided with the reservoirs and remote inlet adapter. Do not over tighten.

Mounting Location:

Master cylinders should be firmly mounted to appropriate pedal assemblies and kept away from heat sources. Use tie straps, or small hose clamps to secure hose when remote reservoir is used. Check to verify that the full stroke of pushrod is unimpeded when depressing brake pedal and that pushrod is allowed to fully retract when brake pedal is released.

Residual Pressure Valves:

Use of an external residual pressure valve should be utilized when the master cylinder is mounted below the horizontal plane of the brake calipers (or drum wheel cylinders). Master cylinder internal residual pressure valves should **not** be used.

Bleeding Instructions:

Master cylinders should be bled while mounted to the brake pedal assembly. **NOTE:** *The master cylinder includes a bleed screw for easy in-place bleeding and that either outlet may be used for the bleed screw/outlet fitting.* Connect all brake lines after the master cylinder is installed, but prior to bleeding. Review the following steps:

- Connect a clear bleed hose with catch bottle to master cylinder bleed screw.
- Wilwood Hi-Temp° 570 Racing Brake Fluid or EXP 600 Plus for extreme performance situations (or alternate high temperature DOT 3, DOT 4 or DOT 5.1 brake fluid) is highly recommended for race cars and high performance vehicles where brake temperatures exceed normal operating conditions. **NOTE:** *Silicone DOT 5 brake fluid is **NOT** recommended for racing or performance driving.*
- Fill reservoir with Racing Brake Fluid.
- Open master cylinder bleed screw.
- Gently depress brake pedal.
- Close master cylinder bleed screw and gently release brake pedal.
- Repeat the above steps until fluid from master cylinder is free of air. Close master cylinder bleed screw.
- To properly bleed the brake system, begin with the caliper farthest from the master cylinder. Bleed the outboard bleed screw first, then the inboard. Repeat the procedure until all calipers in the system are bled, ending with the caliper closest to the master cylinder. **NOTE:** *When using a new master cylinder, it is important to bench bleed the master cylinder first.*
- If the master cylinder is mounted lower than the disc brake calipers, some fluid flowback to the master cylinder reservoir may occur, thus creating a vacuum effect that retracts the caliper pistons into the housing. This will cause the pedal to go to the floor on the first stroke until it has "pumped up" and has moved all the pistons out against the pad again. A Wilwood in-line two pound residual pressure valve, installed near the master cylinder will stop the fluid flowback and keep the pedal firm and responsive.
- Test the brake pedal. It should be firm, not spongy and stop at least 1 inch from the floor under heavy load.
 - If the brake pedal is spongy, bleed the system again.

If the brake pedal is initially firm, but then sinks to the floor, check the system for fluid leaks. Correct the leaks (if applicable) and then bleed the system again.

If the brake pedal goes to the floor and continued bleeding of the system does not correct the problem, a master cylinder with increased capacity (larger bore diameter) will be required. Wilwood offers various lightweight master cylinders with large fluid displacement capacities.

General Information and Installation Instructions (Continued)

Maintenance:

Master cylinder rebuild kits are available for all bore sizes (see ordering information, below) and should be rebuilt periodically (reference Figure 4, the exploded diagram on the back of this sheet). Always inspect master cylinders before and after every race for damage or leakage. When rebuilding master cylinders, take care not to damage piston seals. Test master cylinder before usage. Use Wilwood Hi-Temp° 570 brake fluid as a lubricant when assembling.

Ordering Information:

5/8" Combination Master Cylinder Kit (1.3 stroke)	260-3372	5/8" Combination Rebuild Kit	260-3880
3/4" Combination Master Cylinder Kit (1.1 stroke)	260-3374	3/4" Combination Rebuild Kit	260-3881
13/16" Combination Master Cylinder Kit (1.1 stroke)	260-5920	13/16" Combination Rebuild Kit	260-5921
7/8" Combination Master Cylinder Kit (1.2 stroke)	260-3376	7/8" Combination Rebuild Kit	260-3882
1" Combination Master Cylinder Kit (1.0 stroke)	260-3378	1" Combination Rebuild Kit	260-3883
1-1/8" Combination Master Cylinder Kit (1.0 stroke)	260-3380	1-1/8" Combination Rebuild Kit	260-3884

If after following the instructions, you still have difficulty in installing or bleeding your Wilwood master cylinder, consult your local chassis builder, or retailer where the kit was purchased for further assistance.

Mounting Requirements, Variations

FOUR DIFFERENT MASTER CYLINDER COMBINATIONS AVAILABLE IN ONE KIT

Wilwood's new master cylinder combination kit can be mounted with the reservoir on the master cylinder body "direct mount" (Figure 1), or the reservoir positioned at a convenient remote location "remote mount" (Figure 2), and then connected via a flexible hose.

Both versions can utilize either a large or small mount reservoir (included in the kit), as your application warrants. Refer to Figure 3, page 4 for the minimum mounting requirements before installation begins.

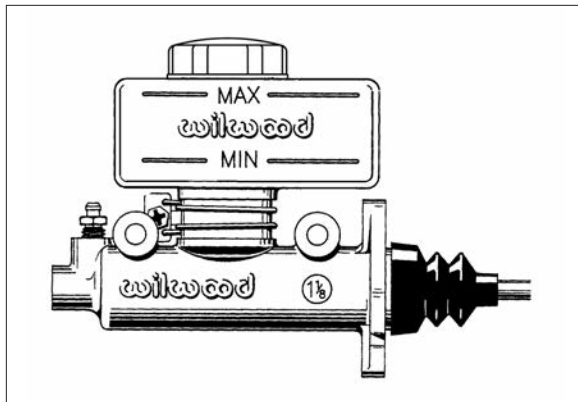

Figure 1. Direct Mounted Master Cylinder

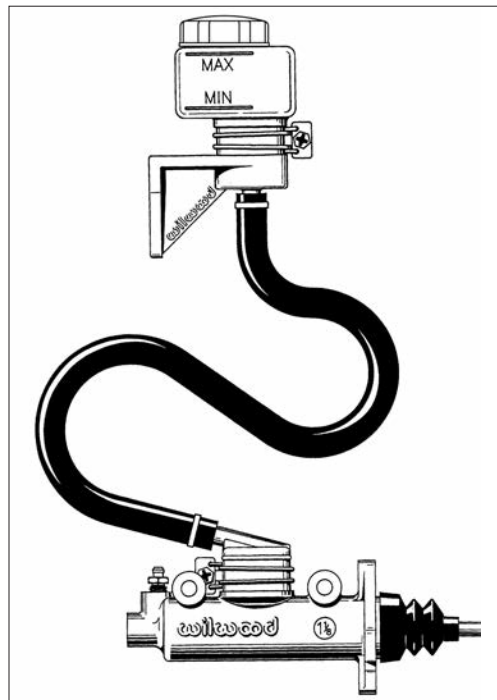

Figure 2. Remote Mounted Master Cylinder

Mounting Requirements, Variations (Continued)

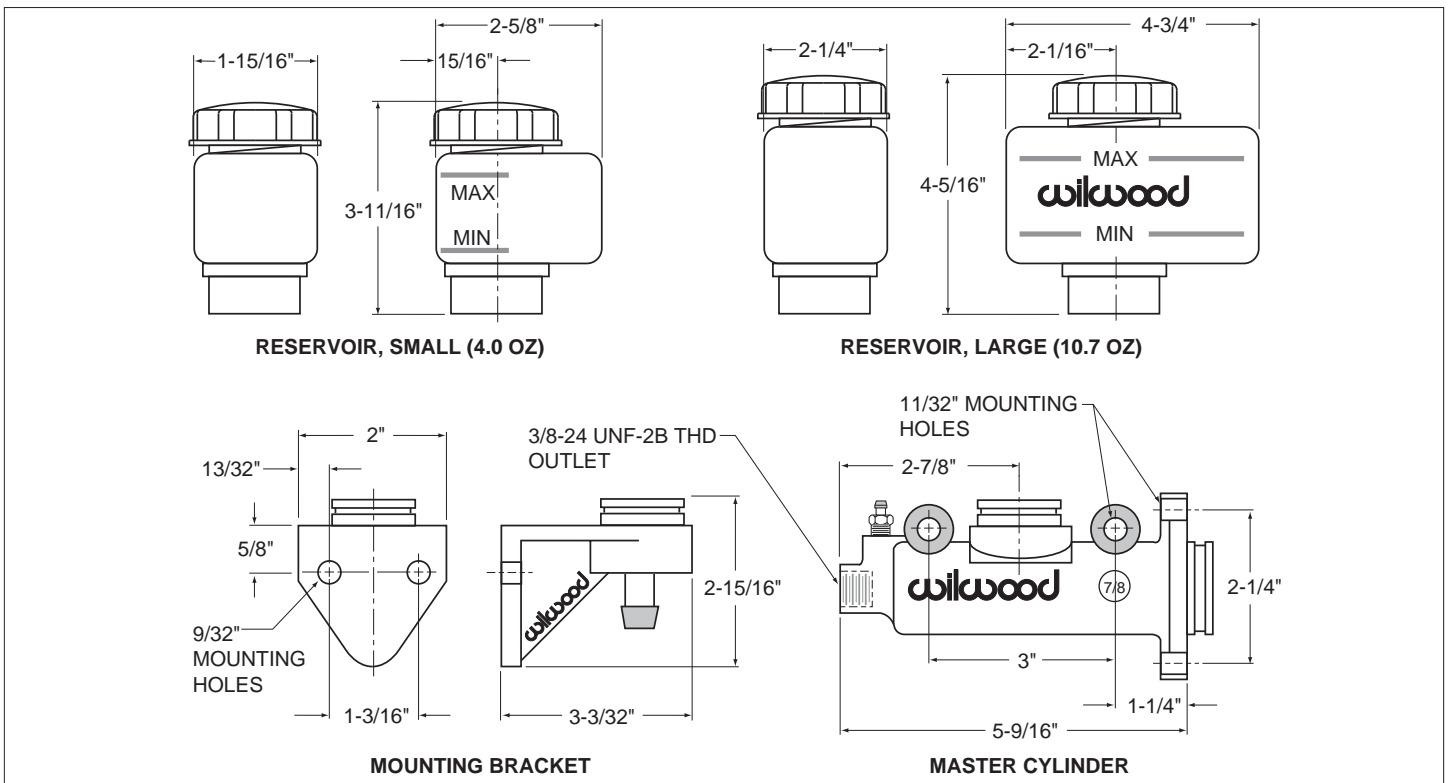

Figure 3. Minimum Mounting Requirements for Mounting Bracket, Master Cylinder and Reservoirs

Exploded Diagram

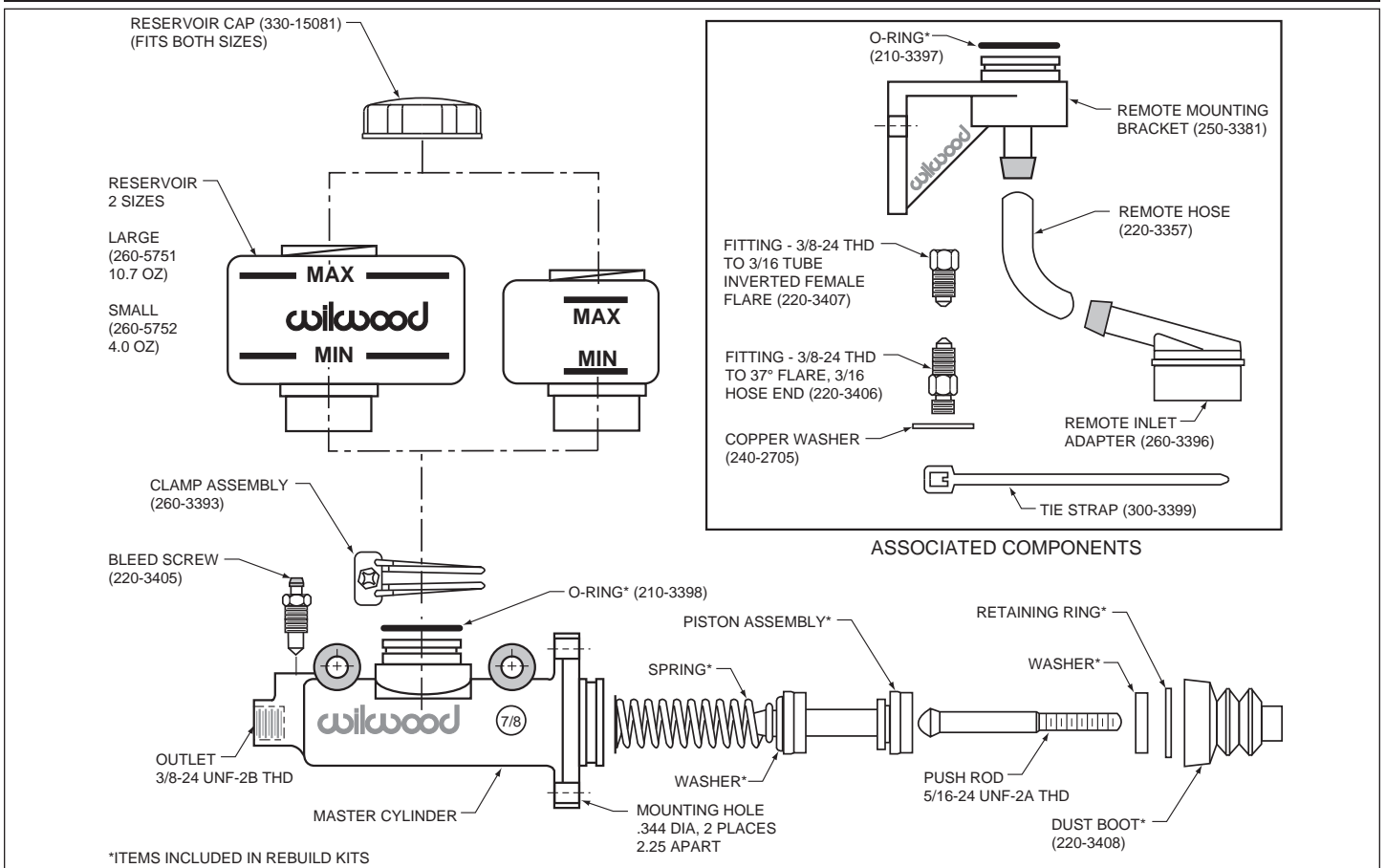

Figure 4. Master Cylinder and Associated Components

Brake Testing

WARNING • DO NOT DRIVE ON UNTESTED BRAKES BRAKES MUST BE TESTED AFTER INSTALLATION OR MAINTENANCE MINIMUM TEST PROCEDURE

- Make sure pedal is firm: Hold firm pressure on pedal for several minutes, it should remain in position without sinking. If pedal sinks toward floor, check system for fluid leaks. DO NOT drive vehicle if pedal does not stay firm or can be pushed to the floor with normal pressure.
- At very low speed (2-5 mph) apply brakes hard several times while turning steering from full left to full right, repeat several times. Remove the wheels and check that components are not touching, rubbing, or leaking.
- Carefully examine all brake components, brake lines, and fittings for leaks and interference.
- Make sure there is no interference with wheels or suspension components.
- Drive vehicle at low speed (15-20 mph) making moderate and hard stops. Brakes should feel normal and positive. Again check for leaks and interference.
- Always test vehicle in a safe place where there is no danger to (or from) other people or vehicles.
- Always wear seat belts and make use of all safety equipment.

Pad and Rotor Bedding

BEDDING STEPS FOR NEW PADS AND ROTORS – ALL COMPOUNDS

Once the brake system has been tested and determined safe to operate the vehicle, follow these steps for the bedding of all new pad materials and rotors. These procedures should only be performed on a race track, or other safe location where you can safely and legally obtain speeds up to 65 MPH, while also being able to rapidly decelerate.

- Begin with a series of light decelerations to gradually build some heat in the brakes. Use an on-and-off the pedal technique by applying the brakes for 3-5 seconds, and then allow them to fully release for a period roughly twice as long as the deceleration cycle. If you use a 5 count during the deceleration interval, use a 10 count during the release to allow the heat to sink into the pads and rotors.
- After several cycles of light stops to begin warming the brakes, proceed with a series of medium to firm deceleration stops to continue raising the temperature level in the brakes.
- Finish the bedding cycle with a series of 8-10 hard decelerations from 55-65 MPH down to 25 MPH while allowing a proportionate release and heat-sinking interval between each stop. The pads should now be providing positive and consistent response.
- If any amount of brake fade is observed during the bed-in cycle, immediately begin the cool down cycle.
- Drive at a moderate cruising speed, with the least amount of brake contact possible, until most of the heat has dissipated from the brakes. Avoid sitting stopped with the brake pedal depressed to hold the car in place during this time. Park the vehicle and allow the brakes to cool to ambient air temperature.

COMPETITION VEHICLES

- If your race car is equipped with brake cooling ducts, blocking them will allow the pads and rotors to warm up quicker and speed up the bedding process.
- Temperature indicating paint on the rotor and pad edges can provide valuable data regarding observed temperatures during the bedding process and subsequent on-track sessions. This information can be highly beneficial when evaluating pad compounds and cooling efficiencies.

Pad and Rotor Bedding (Continued)

POST-BEDDING INSPECTION – ALL VEHICLES

- After the bedding cycle, the rotors should exhibit a uniformly burnished finish across the entire contact face. Any surface irregularities that appear as smearing or splotching on the rotor faces can be an indication that the brakes were brought up to temperature too quickly during the bedding cycle. If the smear doesn't blend away after the next run-in cycle, or if chatter under braking results, sanding or resurfacing the rotors will be required to restore a uniform surface for pad contact.

PRE-RACE WARM UP

- Always make every effort to get heat into the brakes prior to each event. Use an on-and-off the pedal practice to warm the brakes during the trip to the staging zone, during parade laps before the flag drops, and every other opportunity in an effort to build heat in the pads and rotors. This will help to ensure best consistency, performance, and durability from your brakes.

DYNO BEDDED COMPETITION PADS AND ROTORS

- Getting track time for a proper pad and rotor bedding session can be difficult. Wilwood offers factory dyno-bedded pads and rotors on many of our popular competition pads and **Spec 37** GT series rotors. Dyno-bedded parts are ready to race on their first warm up cycle. This can save valuable time and effort when on-track time is either too valuable or not available at all, Dyno-bedding assures that your pads and rotors have been properly run-in and are ready to go. Contact your dealer or the factory for more information on Wilwood Dyno-Bedding services.

NOTE:

NEVER allow the contact surfaces of the pads or rotors to be contaminated with brake fluid. Always use a catch bottle with a hose to prevent fluid spill during all brake bleeding procedures.

Connect with Wilwood

Wilwood Facebook



Wilwood Twitter



Wilwood YouTube



Associated Components

<u>PART NO.</u>	<u>DESCRIPTION</u>
260-13706	Wilwood Residual Pressure Valve (2 lb for disc brakes)
260-13707	Wilwood Residual Pressure Valve (10 lb for drum brakes)
260-8419	Wilwood Proportioning Valve, Knob Style
260-8420	Wilwood Proportioning Valve, Lever Style
260-11179	Wilwood Combination Proportioning Valve with Light Switch
290-0632	Wilwood Racing Brake Fluid (Hi-Temp° 570) (12 oz)
290-6209	Wilwood Racing Brake Fluid (EXP 600 Plus) (16.9 oz)
340-13831	Wilwood Floor Mount Brake Pedal (with balance bar)
340-13832	Wilwood Swing Mount Brake Pedal (with balance bar)
260-6764	Wilwood 3/4 inch High Volume Aluminum Master Cylinder
260-6765	Wilwood 7/8 inch High Volume Aluminum Master Cylinder
260-6766	Wilwood 1 inch High Volume Aluminum Master Cylinder
260-4893	1-1/16 inch Tandem Master Cylinder (aluminum housing)
250-2406	Mounting Bracket Kit (tandem master cylinder)
220-0149	Fitting, Straight (1/8-27 NPT to -4)
220-0842	Fitting, 90° Elbow (1/8-27 NPT to -4)
	(Consult the Wilwood Catalog for a complete parts list)