

ASSEMBLY INSTRUCTIONS

FOR

FRONT DISC BRAKE KIT HEAVY DUTY, VENTED ROTOR TYPE

GT CALIPERS

PART NUMBER

140-3320

WARNING

INSTALLATION OF THIS KIT SHOULD **ONLY** BE PERFORMED BY PERSONS EXPERIENCED IN THE INSTALLATION AND PROPER OPERATION OF DISC BRAKE SYSTEMS. IT IS THE RESPONSIBILITY OF THE PERSON INSTALLING ANY BRAKE COMPONENT OR KIT TO DETERMINE THE SUITABILITY OF THE COMPONENT OR KIT FOR THAT PARTICULAR APPLICATION.



FOR OFF ROAD USE ONLY

BEFORE OPERATING VEHICLE, TEST THE BRAKES UNDER CONTROLLED CONDITIONS. MAKE SEVERAL STOPS IN A SAFE AREA FROM LOW SPEEDS AND GRADUALLY WORK UP TO RACING SPEEDS. **DO NOT RACE ON UNTESTED BRAKES!** ALWAYS UTILIZE SAFETY RESTRAINT SYSTEMS WHILE OPERATING VEHICLE.

IMPORTANT

READ DISCLAIMER OF WARRANTY INCLUDED IN THE KIT.

WARNING: Some cleaners may stain or remove the finish on brake system components. Test the cleaner on a hidden portion of the component before general use.

Installation Assembly Diagram and Parts List

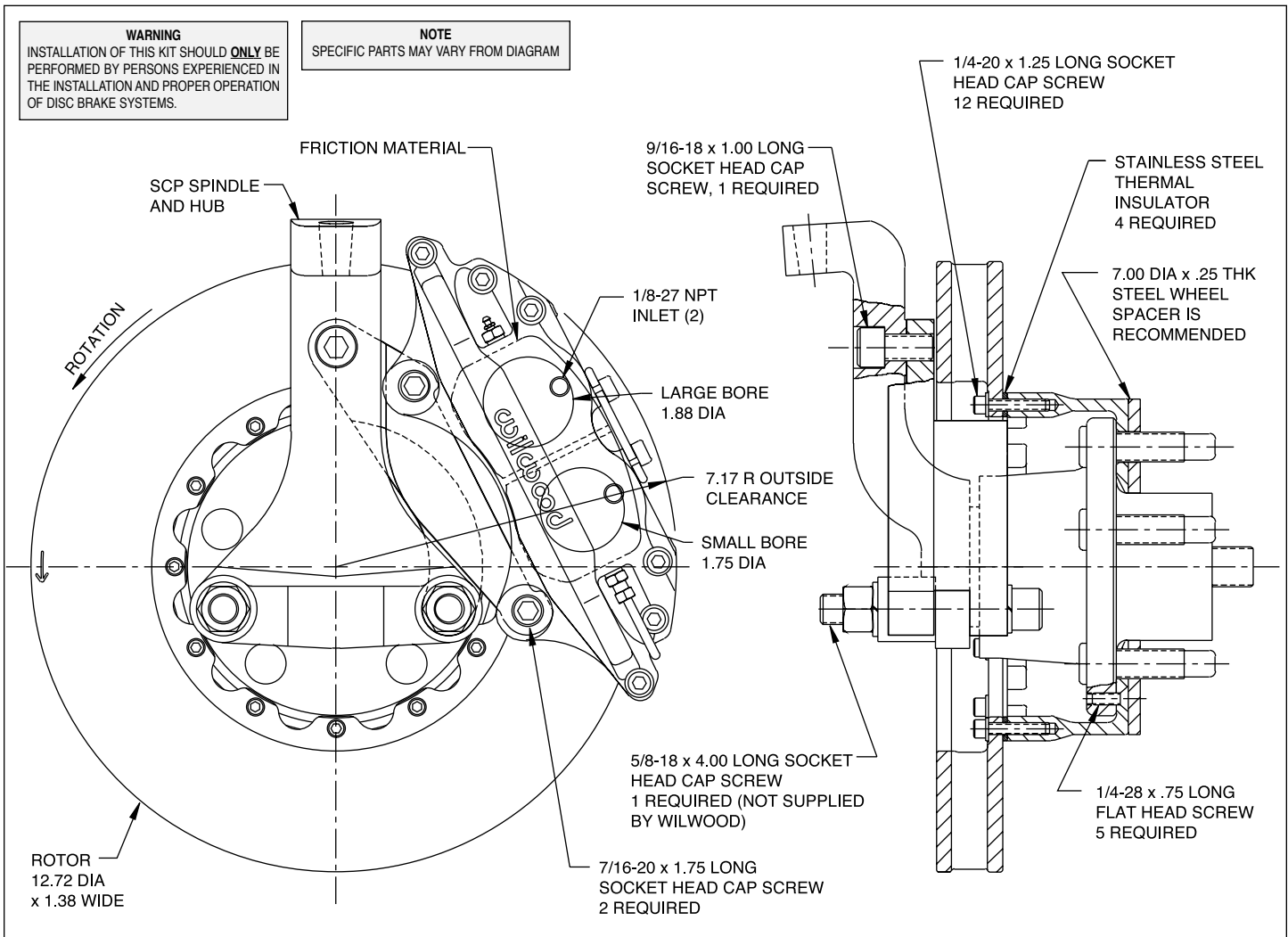

Figure 1. Typical Installation Configuration

<u>ITEM NO.</u>	<u>PART NO.</u>	<u>DESCRIPTION</u>	<u>QTY</u>
1	120-2950-RS*	GT Caliper, Rear Mount, 1.88/1.75 (Right Hand))	1
1	120-2951-RS*	GT Caliper, Rear Mount, 1.88/1.75 (Left Hand)	1
2	160-3314	GT Rotor, Curved Vane, 1.38 x 12.72 (Right Hand)	1
2	160-3315	GT Rotor, Curved Vane, 1.38 x 12.72 (Left Hand)	1
3	170-3316	GT Hat, Front 5 x 5.00 Bolt Circle	2
4	230-3319	Bolt Kit, GT Rotor to Hat with Insulators	2
5	230-2482	Bolt Kit, GT Hat to Hub Mounting	2

*Rear Mount Caliper Shown, Front Mount Calipers are Available.

General Information

General Information:

Installation of this kit should **ONLY** be performed by persons experienced in the installation and proper operation of disc brake systems. Before assembling the Wilwood front disc brake kit, double check the following items to ensure a trouble-free installation.

- This GT kit was designed for use on standard "Stock Car Products" type front spindles and hubs with some minor modifications (see spindle/hub modification instructions/diagram on the following page) and will work with either "front steer" or "rear steer" suspensions.

- Inspect the package contents against the parts list to ensure that all components and hardware are included.

Additional Information, Spindle / Hub Modifications and Assembly Instructions

Additional Information:

•Wilwood aluminum bolt-on caliper mounting brackets allow use of standard “Stock Car Products” style spindles and Wilwood brake kits with no welding required (GT Bracket, Right Hand: P/N 250-2362, Left Hand: P/N 250-2363, GT bracket bolt kit: P/N 230-2484). To simplify installation, special billet aluminum caliper mounting brackets are also available separately from your Wilwood dealer. These brackets are interchangeable from side to side to facilitate front or rear mounting of the calipers, eliminating the need for multiple brake and spindle setups for front or rear steer suspensions.

•It is recommended that GT rear disc brake kits be used in conjunction with the GT front disc brake kit to achieve optimal stopping power and a balanced braking system. Contact your Wilwood dealer for technical assistance when selecting the proper rear brake kit.

Spindle Modification:

•Before installation of the GT caliper onto a Stock Car Products spindle, the raised mounting boss on the upper portion of the spindle arm must be removed. Measuring from the machined face of the spindle, mill the boss down to 1.312 inches, ± 0.002 . Refer to figure 2, on the right.

Hub Modification:

•This GT kit uses a small diameter rotor mounting hat to accommodate the larger size friction pads of the GT caliper. To fit the GT hat to the Stock Car Products front hub, the outside diameter (O.D.) of the hub must be reduced. Reduce the O.D. of the hub to 6.205 inches, ± 0.005 . Chamfer the O.D. of the hub to 0.060 inch x 45 degrees. See figure 2, on the right.

Assembly Instructions (number in parenthesis refer to the parts list on the preceding page):

•Position the stainless steel thermal insulators between the rotor (2) and hat (3) and secure rotor to hat using the GT bolt kit (4). Torque bolts to 85 in-lb. Safety wire bolts (4). Insulator must be used to obtain proper rotor alignment and limit heat transfer to the hub.

•If using Wilwood’s GT caliper mounting brackets, install brackets to spindles utilizing the GT bolt kit (P/N 230-2484). The upper bolts should penetrate completely through the clinch nuts or threaded inserts. Torque upper bolts to 105 ft-lb. Torque the lower bolts to Stock Car Products recommended specifications. Safety wire both upper and lower bolts.

•Install the hat/rotor assembly (2 and 3) onto the hubs using the GT bolt kit (5). Torque bolts to 100 in-lb.

•Position caliper (1) over rotor (2) with the bleed screw pointing up so that the rotor turns past the small pistons in the caliper first. Bolt caliper (1) to spindle or mounting bracket using GT bolt kit (P/N 230-2484). Finger tighten. View the rotor (2) through the top of the caliper (1). The rotor (2) should be aligned in the center of the caliper (1). If not, loosen the mounting bolts and adjust the caliper by using 0.032 inch thick shim washers (supplied with the kit). The shim washers should be placed between the caliper (1) and the caliper mounting bracket or spindle. Add as many shim washers as necessary to achieve the correct alignment. Always use the same amount of shims on both the top and bottom caliper mounting bolts. Remove the caliper mounting bolts one at a time and apply red Loctite® 271 to the bolt threads and reinstall. Torque bolts to 42 ft-lb and safety wire.

•Install pads in calipers (1) and secure with quick release retainers.

•Repeat the above steps for the other wheel.

•**NOTE:** 1/4 inch steel wheel spacers should be positioned between the wheel and the hat. Wheels installed directly against the hat could work loose and/or cause damage to the hat.

•**NOTE:** The caliper inlet hole has a 1/8-27 NPT thread. A steel adapter fitting, straight or 90° elbow, should be installed in the caliper. Stainless steel braided flex line with enough length to allow the wheels to turn lock to lock without straining or pinching the line should be used to fabricate new brake hoses. **RUBBER BRAKE HOSES SHOULD NOT BE USED.**

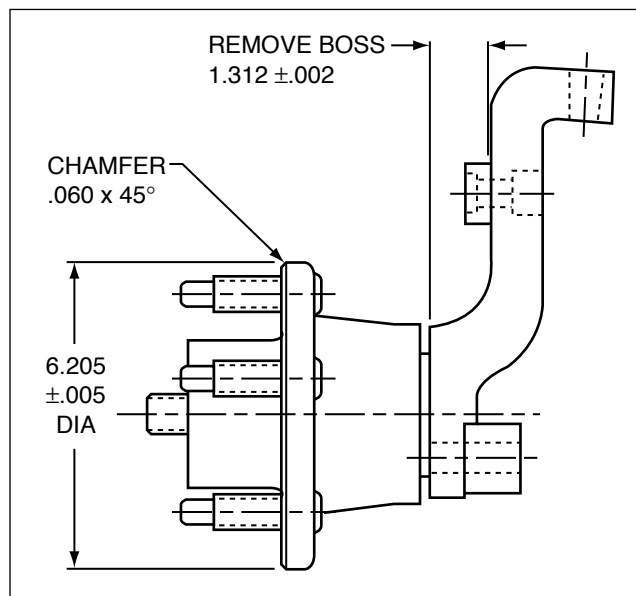

Figure 2. Spindle and Hub Modifications

Brake Bias Information and Recommendations

- With the Wilwood disc brake system completely installed, use either of the two methods listed to balance the brake bias front to rear.
 - The Most Efficient Method:**
A Wilwood brake pedal/balance bar assembly (either floor or swing mount) and two single master cylinders (either two 7/8 inch or two 1 inch) mounted side by side. Dialing the balance bar left or right transfers the pressure from front to rear, or rear to front and allows the smallest of pressure adjustments to be made without any loss to the overall brake system line pressure.
 - The More Popular Method:**
An OEM 1-1/16 inch bore dual outlet master cylinder with a Wilwood adjustable proportioning valve plumbed into either the front or rear brake line. **NOTE:** A proportioning valve is an in-line pressure reducing device. Output pressure is reduced proportionally to input pressure. Net result is that the line pressure is reduced, forcing the remaining brakes to do more of the work.
- Fill and bleed the new system with Wilwood Hi-Temp^o 570 grade fluid or higher. For severe braking or sustained high heat operation, use Wilwood EXP 600 Plus Racing Brake Fluid. Used fluid must be completely flushed from the system to prevent contamination. **NOTE:** Silicone DOT 5 brake fluid is **NOT** recommended.
- To properly bleed the brake system, begin with the caliper farthest from the master cylinder. Bleed the outboard bleed screw first, then the inboard. Repeat the procedure until all calipers in the system are bled, ending with the caliper closest to the master cylinder. **NOTE:** When using a new master cylinder, it is important to bench bleed the master cylinder first.
- If the master cylinder is mounted lower than the disc brake calipers, some fluid flowback to the master cylinder reservoir may occur, creating a vacuum effect that retracts the caliper pistons into the housing. This will cause the pedal to go to the floor on the first stroke until it has "pumped up" and moved all the pistons out against the pad again. A Wilwood in-line two pound residual pressure valve, installed near the master cylinder will stop the fluid flowback and keep the pedal firm and responsive.
- Test the brake pedal. It should be firm, not spongy and stop at least 1 inch from the floor under heavy load.
 - If the brake pedal is spongy, bleed the system again.
 - If the brake pedal is initially firm, but then sinks to the floor, check the system for fluid leaks. Correct the leaks (if applicable) and then bleed the system again.
 - If the brake pedal goes to the floor and continued bleeding of the system does not correct the problem, a master cylinder with increased capacity (larger bore diameter) will be required. Wilwood offers various lightweight master cylinders with large fluid displacement capacities.
- NOTE:** With the installation of after market disc brakes, the wheel track may change depending on the application. Check your wheel offset before final assembly.
- On some models of disc brake spindles there are "ears" where the OEM calipers were mounted and these "ears" interfere with the assembly of the Wilwood disc brake kit. If it becomes necessary to remove these "ears", remove as little as possible being careful not to cut away any of the mounting holes that may be required to bolt on the caliper mounting bracket.
- If after following the instructions, you still have difficulty in assembling or bleeding your Wilwood disc brakes, consult your local chassis builder, or retailer where the kit was purchased for further assistance.

PAD BEDDING PROCEDURE:

- Pump brakes at low speed to assure proper operation. On the race track, or other safe location, make a series of hard stops until some brake fade is experienced. Allow brakes to cool while driving at moderate speed to avoid use of the brakes. This process will properly burnish the brake pads, offering maximum performance.

Associated Components

PART NO.	DESCRIPTION
170-3317	GT (front) Hat, 2.12 Offset, .50 inch Thick Face
170-3788	GT (front) Hat, 2.12 Offset, .25 inch Thick Face
260-3500	Wilwood Dynamic Bleed System
290-0632	Wilwood Racing Brake Fluid (Hi-Temp ^o 570) (12 oz)
340-1285	Wilwood Floor Mount Brake Pedal (with balance bar)
340-1287	Wilwood Swing Mount Brake Pedal (with balance bar)
260-6764	Wilwood 3/4 inch High Volume Aluminum Master Cylinder
260-6765	Wilwood 7/8 inch High Volume Aluminum Master Cylinder
260-6766	Wilwood 1 inch High Volume Aluminum Master Cylinder
160-3854	Heavy Duty GT Curved Vane Rotor, Right Hand
160-3855	Heavy Duty GT Curved Vane Rotor, Left Hand
15B-3995K	Brake Pads, Polymatrix, "B" Compound (axle set of 4)
15C-4042K	Brake Pads, Polymatrix, "C" Compound (axle set of 4)
150-2564K	Brake Pads, PFC 702/83 (axle set of 4)
220-0149	Fitting, Straight (1/8-27 NPT to -4)
220-0842	Fitting, 90° Elbow (1/8-27 NPT to -4)

(Consult the Wilwood Catalog for a complete parts list)

Bolt Torque Specifications

BOLT SIZE	TORQUE
1/4-20	85 in-lb
1/4-28	103 in-lb
5/16-18	180 in-lb
5/16-24	198 in-lb
3/8-16	22 ft-lb
3/8-24	30 ft-lb
7/16-14	42 ft-lb
7/16-20	47 ft-lb
1/2-13	65 ft-lb
1/2-20	77 ft-lb
9/16-12	95 ft-lb
9/16-18	105 ft-lb
5/8-11	110 ft-lb
5/8-18	120 ft-lb

NOTE: This bolt torque specification list is for use with specific grades of bolts as supplied in the particular Wilwood kit and is not intended as a guide for any other application.