



Instructions for Pad Wear Plate Replacement - Prolite Caliper

Notice:

Due to design enhancements, it is necessary to install the enclosed pad wear plates (P/N's 300-5215 and 300-5216) in all **PROLITE** calipers, replacing earlier version pad wear plates.

Installation Instructions:

Using a Torx head wrench, remove the screw that secures the pad wear plate on the inside of the caliper heat shield and slide out the existing pad wear plate. Take one of the new pad wear plates that corresponds to the mounting location of the one that was just removed and insert the plate in place while sliding the mounting tab under the heat shield. Secure in place with the screw and tighten with the Torx head wrench. Repeat this procedure three more times on the remaining pad wear plates.

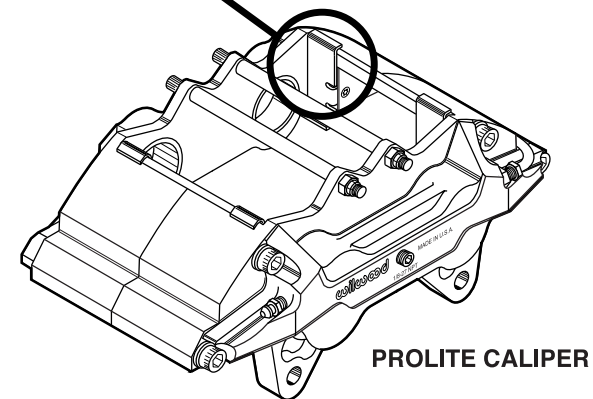
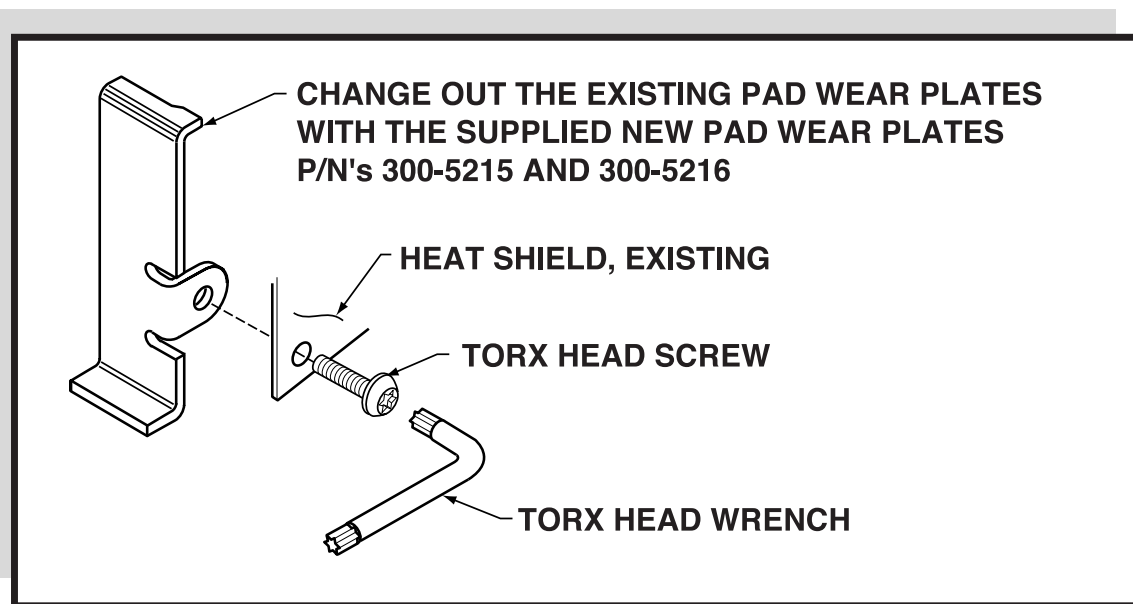

4700 Calle Bolero • Camarillo, CA 93012

Sales: (805) 388-1188 • Fax: (805) 388-4938