

CORVETTE C-4 / C-5 PRO-MATRIX PAD AND ROTOR UPGRADE KITS

Models Covered:

Corvette C-4, Gran Sport and H/D Option	1998 - 1996
Chevrolet Corvette C-5, Z06	1997 - 2004

Kit Features:

- Upgrade from OE pads, rotors, and flex lines for street performance, track day events, and drag racing.
- Retains OE calipers, mounting, and parking brake.
- Fully compatible with ABS and other OE components.
- Two-piece aluminum hat / iron rotor assemblies for C-4 front and rear, C-5 front.
- One piece iron drum / disc for C-5 rear to retain OE park brake assembly.

Component Features:

Directional Vane Rotors

- Directional vane rotors provide increased cooling efficiency over non-directional rotors through increased surface area and air circulation between the rotor faces.
- **SRP** series rotors are drilled and slotted for enhanced pad performance through improved pad cleaning, heat venting, and gas dispersion during braking. The directional drill and slot pattern is complimented with a corrosion resistant e-coated finish to provide an aggressive high tech / custom appearance inside the wheels.
- **GT** series rotors are competition prepared with asymmetrical face slotting, full detail machining, and individual dynamic balancing to deliver the highest degree of durability and thermal stability in sustained high temperature conditions with smooth operation at all speeds.

Aluminum GT Rotor Mounting Hats

- GT forged or billet aluminum rotor hats are lightweight and strong to reduce power robbing rotating weight and strong to handle the increased brake torque.
- Hats are black anodized to resist corrosion and add to the aggressive competition look inside the wheel.

Wilwood PolyMatrix Performance Brake Pads

- SRP rotor kits include PolyMatrix "Q" compound pads. "Q" delivers improved friction and temperature range over OE compounds with the lowest noise and dust levels available from a high performance pad.
- GT rotor kits include PolyMatrix "E" compound pads. "E" is a medium-high temperature race compound with substantially higher friction, increased fade resistance, and longer wear for sustained operating temperatures up to 1000° F.

Mounting Hardware and Plumbing

- Stainless steel, 12 point head, lock wire drilled rotor bolts provide corrosion free, secure mounting of the two piece hat / rotor assemblies.
- DOT approved stainless steel braided flex lines are included to replace the original rubber flex lines. Stainless steel lines reduce compliance under pressure for a firmer pedal feel while greatly enhancing the appearance of the chassis and suspension detail.



Pro-Matrix OE Front Upgrade Pad and Rotor Kit
with SRP Rotor



Pro-Matrix C-4 OE Rear Upgrade Pad and Rotor Kit
with SRP Rotor

WARNING

INSTALLATION OF THIS KIT SHOULD **ONLY** BE PERFORMED BY PERSONS EXPERIENCED IN THE INSTALLATION AND PROPER OPERATION OF DISC BRAKE SYSTEMS. IT IS THE RESPONSIBILITY OF THE PERSON INSTALLING ANY BRAKE COMPONENT OR KIT TO DETERMINE THE SUITABILITY OF THE COMPONENT OR KIT FOR THAT PARTICULAR APPLICATION.

RACING EQUIPMENT AND BRAKES MUST BE MAINTAINED AND SHOULD BE CHECKED REGULARLY FOR FATIGUE, DAMAGE AND WEAR.

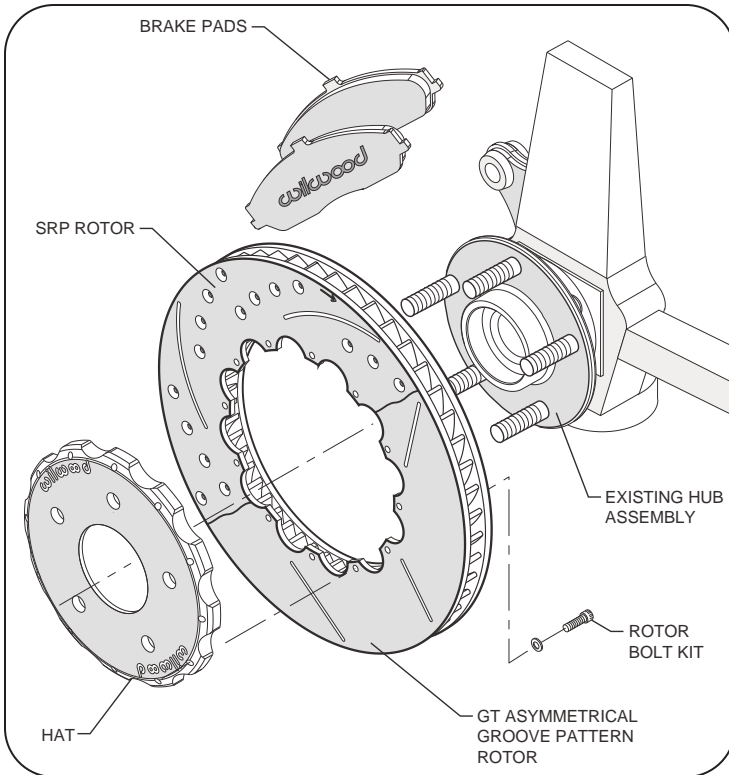

Typical C-4 / C-5 Front Installation Diagram

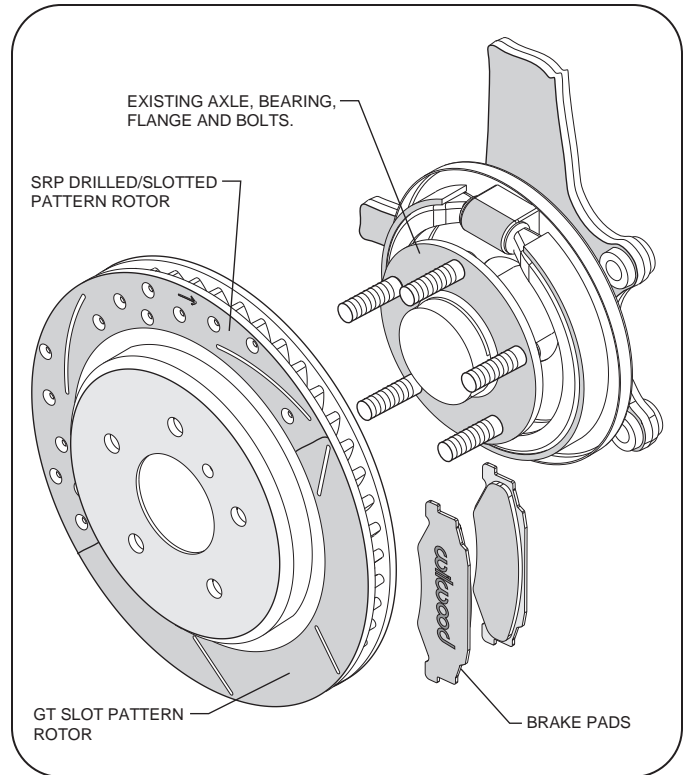

Typical C-5 Rear Installation Diagram

ORDERING INFORMATION:

MODEL	YEAR	ROTOR SIZE TYPE	GT ROTOR KIT	SRP ROTOR KIT
Corvette C-4, Gran Sport & H/D Option Only	1988-1996	13" Front	140-8313	140-8313-D
Corvette C-4, All Models	1988-1996	12" Rear	140-8314	140-8314-D
Corvette C-5, Z06	1997-2004	13" Front	140-8009	140-8009-D
Corvette C-5, Z06	1997-2004	12" Rear	140-8010	140-8010-D

ORDERING INFORMATION: USER SERVICEABLE COMPONENTS, PART NUMBER:

KIT BASE PART NO.	GT ROTOR-R/L	SRP ROTOR-R/L	AXLE SET PADS-GT	AXLE SET PADS-SRP	HAT	ROTOR BOLT KIT	FLEX LINE KIT
140-8009	160-7742/43	160-7744/45	15E-7442K	15Q-8012K	170-7746	230-8008	220-8021
140-8010	160-8013/14	160-7767/68	15E-7441K	15Q-8011K	—	—	220-8072
140-8313	160-8508/09	160-8510/11	15E-8298K	15Q-8481K	170-8492	230-8008	220-8516
140-8314	160-8494/95	160-8496/97	15E-8299K	15Q-8482K	170-8493	230-8390	220-8517

Wilwood Brake Fluid

For best results, flush and bleed your brake system with Wilwood brake fluid. Wilwood fluids are specially formulated to resist fade and aeration in extreme conditions. Hi-Temp 570° exceeds all DOT 3 specifications and is recommended for street performance and drag racing. EXP 600 Plus exceeds DOT 4 specifications and boasts the highest dry point available. It is recommended for road racing and all other sustained high heat applications.