

FRONT DISC BRAKE UPGRADE KIT FOR 1982-1986 JEEP WRANGLER CJ

Models Covered:

- 1982 - 1986 Jeep Wrangler CJ

Kit Features:

- Upgrade from OE calipers to Forged Billet Narrow Superlite 4R (FNSL4R) four piston calipers for either street or off-road.
- Choose either 12.19" diameter, 1.10" thick HP plain face or SRP drilled and slotted rotors
- Simple bolt-on installation with no modifications required.
- Fully compatible with ABS and OE master cylinder output.
- Always check the wheel clearance diagram included with the installation instructions to ensure adequate wheel clearance.

Component Features:

FNSL4R Forged Billet Radial Mount Calipers

- Competition proven forged billet bodies demonstrates superior strength and resistance to deflection and separation under high load.
- FNSL4R calipers use stainless steel pistons to resist corrosion and reduce heat transfer from the pads.
- The internal piston seal-in-bore design adds proven durability with keeping the fluid in and dirt out without the need for external boot seals.
- Spring loaded SRS bridge plates dampen noise and engagement harmonics while protecting the caliper bridge from wear by pad gouging.
- High temperature, fluid resistant high gloss black finish with Wilwood's signature logo is standard. Optional red calipers are also available.

HP Straight or SRP Directional Vane 12.19" Diameter x 1.10" Thick Rotors

- Whether straight or directional vane, these rotors provide the highest degree of cooling efficiency with increased surface area and improved air circulation between the rotor faces.
- HP rotors provide high performance and rugged durability for a wide range of competition, performance, sport driving, and off-road applications. Rotors are cast from premium grade, long grain carbon iron.
- Drilled rotor kits feature our signature SRP performance drilled and slotted rotors with a durable e-coat finish. E-coat seals the casting and prevents corrosion in all areas of the rotor not swept clean by the brake pads. This durable finish will maintain the high tech styling and appearance of the rotors inside your wheels for many miles down the road.

Forged Aluminum GT Mounting Hats

- Forged aluminum rotor mount hats help reduce weight with the strength to handle the exceptional brake torque delivered by the FNSL4R caliper.
- Black e-coat finish resists corrosion while adding to the aggressive competition look inside the wheel.

Wilwood BP-10 "Smart Pads"

- Kit includes BP-10 metallic-composite compound "Smart Pads". BP-10 delivers the increased friction, higher fade resistance, and longer wear of an off-road pad, with virtually noise and dust free performance for the street.
- Optional compounds are available to suit the braking requirements at all levels of severe duty, on or off road.

Radial Mounting Hardware and Plumbing

- Radial mounting provides secure attachment directly to the OE mount with two planes of adjustment for precise alignment over the rotor. Brackets, premium grade fasteners, and alignment shims are included in each kit.
- Stainless steel braided competition flex line kits are necessary to connect the Wilwood calipers to the brake system and must be ordered separately. Order part number 220-12763.

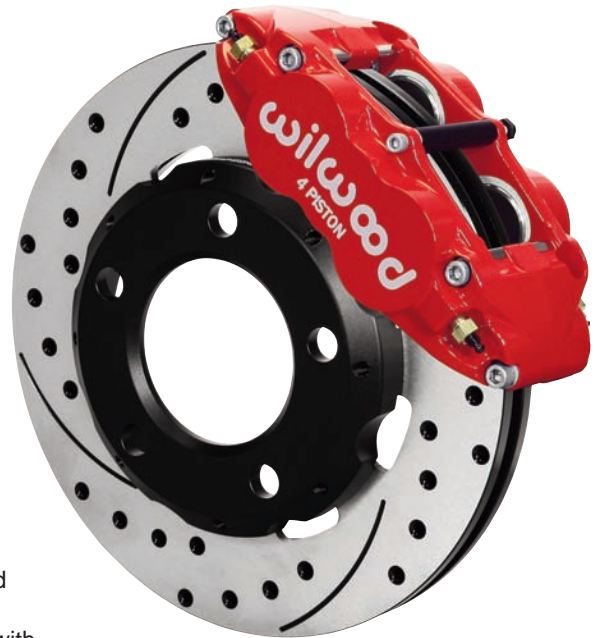

**Jeep Front Kit Assembly with SRP
Drilled and Slotted Rotor**

Download high resolution photo,
[click here](#)

WARNING
 INSTALLATION OF THIS KIT SHOULD **ONLY** BE PERFORMED BY PERSONS EXPERIENCED IN THE INSTALLATION AND PROPER OPERATION OF DISC BRAKE SYSTEMS.

NOTE
 SPECIFIC PARTS MAY VARY FROM DIAGRAM

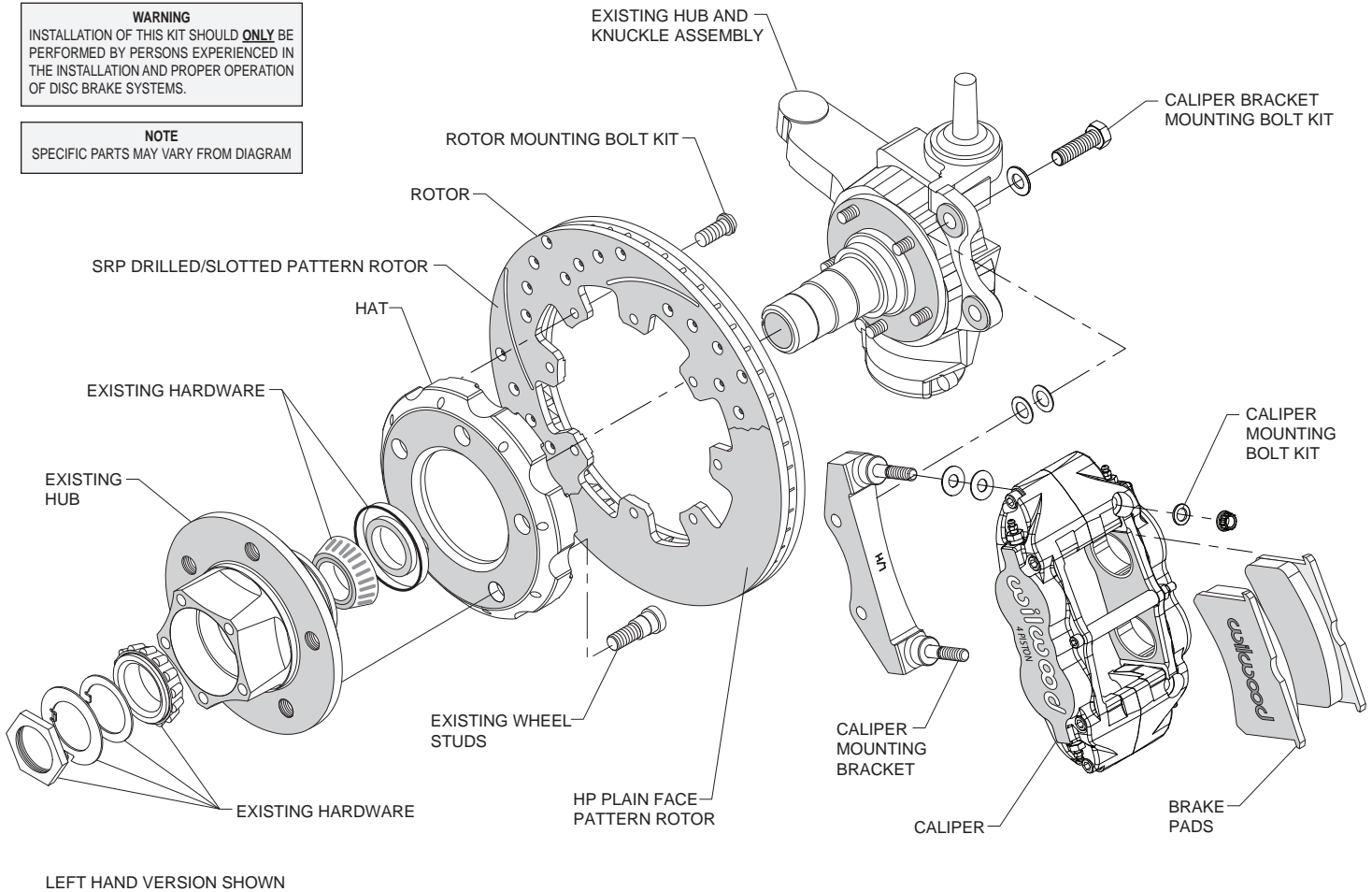

Typical Installation Diagram • Part Number **140-12613 / -D**

ORDERING INFORMATION:

PART NUMBER

DESCRIPTION

140-12613	Front Kit, Jeep CJ, FNSL4R Caliper, 12.19" HP Rotor
140-12613-D	Front Kit, Jeep CJ, FNSL4R Caliper, 12.19" SRP Drilled and Slotted Rotor
140-12613-R	Front Kit, Jeep CJ, FNSL4R Caliper, 12.19" HP Rotor, Red Caliper
140-12613-DR	Front Kit, Jeep CJ, FNSL4R Caliper, 12.19" SRP Drilled and Slotted Rotor, Red Caliper



Need additional information - fast? Utilizing your Smartphone, scan the image at the left to jump to our web site. This code takes you to our home page and social media sites where information is just a click away, [or click here.](#)