



CORVETTE C-5 / C-6 • SUPERLITE 4R BIG BRAKE REAR PARKING BRAKE HAT KIT

Models Covered:

Chevrolet Corvette C-5
Chevrolet Corvette C-6

1997 - 2004
2005 - Present

Kit Features:

- Choice of 13.00 or 14.00 inch SRP or GT series rotors
- Use in conjunction with OE internal park brake assembly
- Upgrade from OE brakes for street performance and track day events
- Choice of black or red forged billet Superlite 4R calipers
- Full bolt-on installation compatible with ABS and OE master cylinder output
- Bias matched for use with SL6R Big Brake front kits

Component Features:

Forged Billet Superlite 4R Radial Mount Calipers

- Fully machined billet forgings, based on a race proven radial mount design, demonstrate superior strength and resistance to deflection under high loads.
- Bias matched clamping force is delivered from 4 stainless steel pistons that reduce heat transfer and resist corrosion.
- Spring loaded stainless steel "SRS" bridge plates reduce noise by dampening engagement harmonics and stopping pad rattle. Bridge wear caused by gouging at the pad trailing edge is also eliminated.
- Center bridge bolt design adds additional strength against caliper separation under load while allowing easy access for pad service without caliper removal.
- Available with the standard high luster black anodizing or special order with a brake fluid and temperature resistant bright red coating.



Corvette C-5 / C-6 Big Brake
Rear Kit with SRP Rotor

Directional Vane 13.00" or 14.00" Rotors

- Directional vane rotors demonstrate high cooling efficiency through increased surface area and air circulation between the rotor faces. 13.00" rotors feature 48 full width vanes. 14.00" rotors with 72 staggered width vanes offer the highest cooling capacity for sustained high heat applications.
- SRP series rotors are drilled and slotted for enhanced pad performance through improved pad cleaning, heat venting, and gas dispersion during braking. The drill and slot pattern is complimented with a corrosion resistant silver zinc finish to provide an aggressive high tech / custom appearance inside the wheels.
- GT series rotors are competition prepared with asymmetrical face slotting, full detail machining, and individual dynamic balancing to deliver the highest degree of durability and thermal stability in sustained high temperature conditions and smooth operation at all speeds.
- Choice of 13.00 or 14.00 inch rotors provide performance upgrade options with increased brake leverage over the factory standard 12.00 or 13.00 inch Z51 Sport Package rear systems.

Rotor Mounting Hats / Parking Brake Drum

- High strength cast steel hats provide the contact drum for the OE parking brake shoes.
- Two-piece hat / rotor assemblies allow simple bolt-on of optional rotor types and sizes without the need to replace the hat section.
- Hats are black-zinc coated to resist corrosion and add to the aggressive competition look inside the wheel.

Wilwood High Performance Brake Pads

- SRP rotor kits include PolyMatrix "Q" compound pads. "Q" delivers improved friction and temperature range over OE compounds with the lowest noise and dust levels available from a high performance pad.
- GT rotor kits include BP-10 compound "Smart Pads". BP-10 provides middle to upper temperature range friction and fade resistance found in metallic based race compounds, but with the low temperature response, low dust, and quiet engagement of a street compound pad.

Mounting Hardware and Plumbing

- Race proven radial mount system includes brackets, high strength fasteners, washers, and alignment shims for an accurate and secure installation.
- Optional stainless steel braided competition flex line kits with machine crimped ends include the fittings necessary to connect the calipers with the OE brake line fitting at the chassis. Flex line kits must be ordered separately.

Please check the diagram on the back of this page for minimum inside wheel clearance requirements

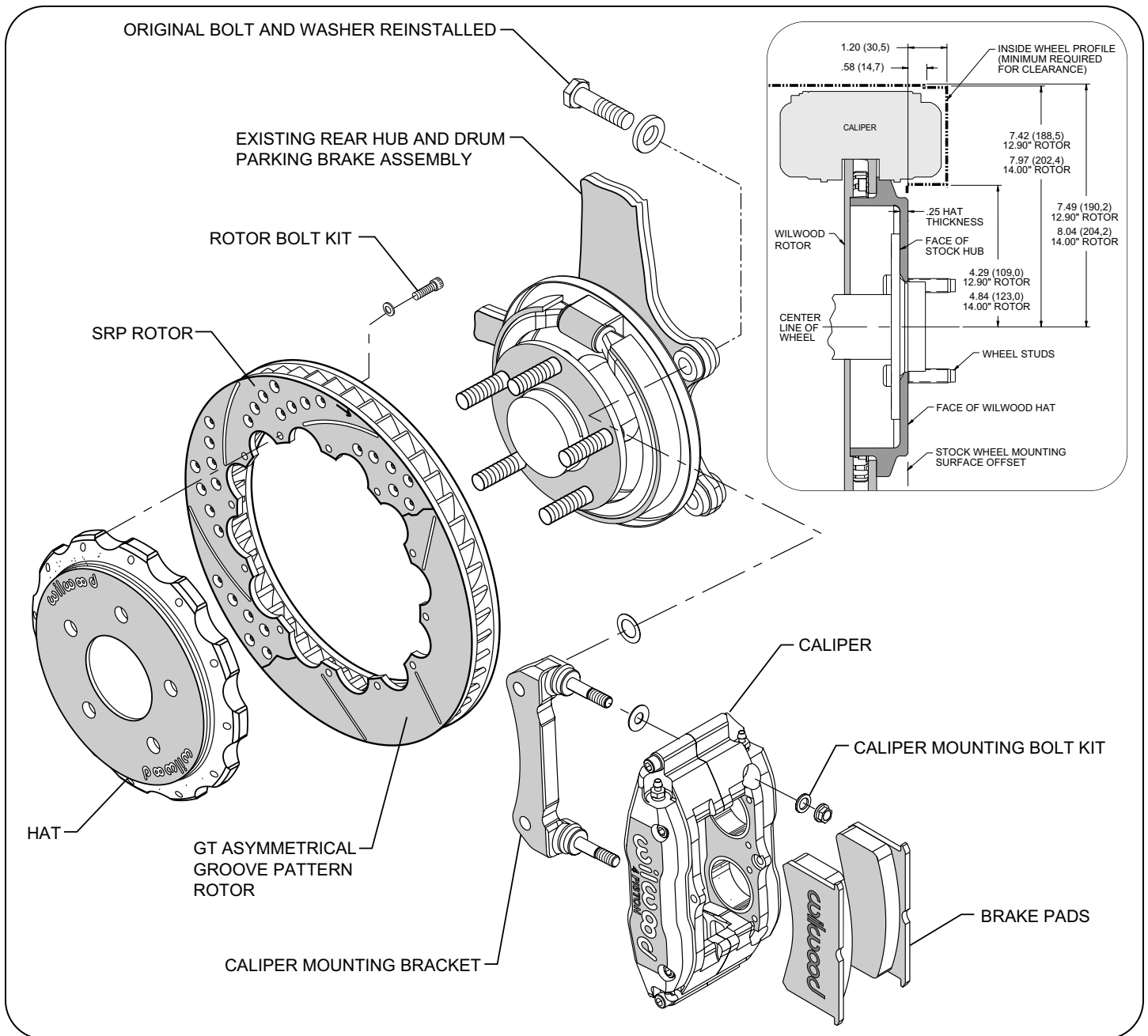

Typical Installation Diagram, Major Components Identified. Minimum Wheel Fit Dimensions Shown Inset

ORDERING INFORMATION: BRAKE AND FLEX LINE KITS:

MAKE / MODEL	YEAR	ROTOR SIZE	KIT PART NUMBERS		
			GT ROTOR KIT	SRP ROTOR KIT	FLEX LINE KITS
Corvette C-5	1997 - 2004	13.00	140-8032	140-8032-D	220-8177
Corvette C-5	1997 - 2004	14.00	140-9119	140-9119-D	220-8177
Corvette C-6	2005 - Present	13.00	140-8032	140-8032-D	220-9101
Corvette C-6	2005 - Present	14.00	140-9119	140-9119-D	220-9101

ORDERING INFORMATION, USER SERVICEABLE COMPONENTS:

PART NUMBER	CALIPER	GT ROTOR-R/L	SRP ROTOR-R/L	AXLE SET PADS	HAT	ROTOR BOLT KIT	BRACKET KIT (EA)
140-8032	120-8062-R/L	160-7597/98	—	150-8855K	170-8169	230-8217	250-8168
140-8032-D	120-8062-R/L	—	160-8006/07	15Q-6828K	170-8169	230-8217	250-8168
140-9119	120-8062-R/L	160-8402/03	—	150-8855K	170-8169	230-8217	250-9120
140-9119-D	120-8062-R/L	—	160-8400/01	15Q-6828K	170-8169	230-8217	250-9120