

NISSAN 350/370Z • INFINITI G35/G37 DYNAPRO BIG BRAKE REAR HAT KIT

Models Covered:

Nissan 350/370Z
Infiniti G35/G37

2003 - Present
2003 - Present

Kit Features:

- Bolt-on system for street and track upgrades from OE calipers and 308 mm discs to forged billet four piston calipers and 328 mm discs.
- Retains full use of OE parking brake assembly.
- Compatible with ABS and OE master cylinder output.
- Matched performance for front 350Z/G35 kits 140-9190 and 140-9192, and front 370Z/G37 kits 140-11583 and 140-11584.
- Designed for use with 17" and larger wheels with minimum clearances as per the diagram on page 2.

Component Features:

Billet DynaPro Four Piston Radial Mount Calipers

- Rigid FEA designed forged billet body provides confident pedal response with high resistance to deflection or body separation under load.
- Four dust boot alloy pistons generated balanced clamping force and provide corrosion free durability in all conditions.
- Quick-Clip pad retainers allow easy access for pad service without caliper removal.
- Spring loaded stainless steel SRS bridge plates reduce noise by stopping pad rattle and damping the engagement harmonics that can contribute to pad squeal. Bridge wear from gouging at the pad trailing edge is also eliminated.
- Standard calipers feature Wilwood's signature and high gloss black powder coat.
- Optional high gloss red coated calipers are available as an upgrade.



**Nissan/Infiniti Big Brake
Rear Kit with SRP Rotor**

Directional Vane 12.90" Diameter Rotors

- SRP and GT series 12.90" / 328mm rotors provide additional leverage for increased stopping power over the standard OE 12.13" / 308 mm discs.
- Directional vane rotors provide superior cooling efficiency with increased surface area and improved air circulation between the rotor faces.
- SRP series rotors are drilled and slotted to enhance pad performance through improved cleaning, heat venting, and gas dispersion during braking. The directional drill and slot pattern is complimented with a corrosion resistant E-coat finish to provide an aggressive, high tech appearance inside the wheel.
- GT series rotors are competition prepared with asymmetrical face slotting, full detail machining, and individual dynamic balancing to deliver maximum durability and thermal stability in sustained high heat temperature conditions with smooth operation at all speeds.

Parking Brake Drum / Hat

- The two piece rotor and drum / hat assembly allows the use of bolt-on rotors while maintaining full use of the OE internal shoe parking brake.
- Drum / hats are finished with a E-coat finish to resist corrosion and maintain a custom look inside the wheel.

Wilwood BP-10 "Smart Pads"

- All kits include BP-10 metallic-composite compound "Smart Pads". BP-10 delivers the increased friction, higher fade resistance, and longer wear of an entry level track pad, with virtually noise and dust free performance for the street.
- Optional race-only compounds can be ordered to suit the braking requirements at all levels of severe duty and sustained high heat competition.

Mounting Hardware and Plumbing

- Race proven radial mount system provides two planes of adjustment for precise alignment of the caliper and pads over the rotor. Kits include billet brackets, high strength fasteners, washers, and alignment shims for an accurate and secure installation.
- Optional stainless steel flex lines, with machine crimped ends, include the fittings necessary to connect the calipers with the OE brake line fitting at the chassis. Flex line kits must be ordered separately.

Please check the diagram on the back of this page for minimum inside wheel clearance requirements

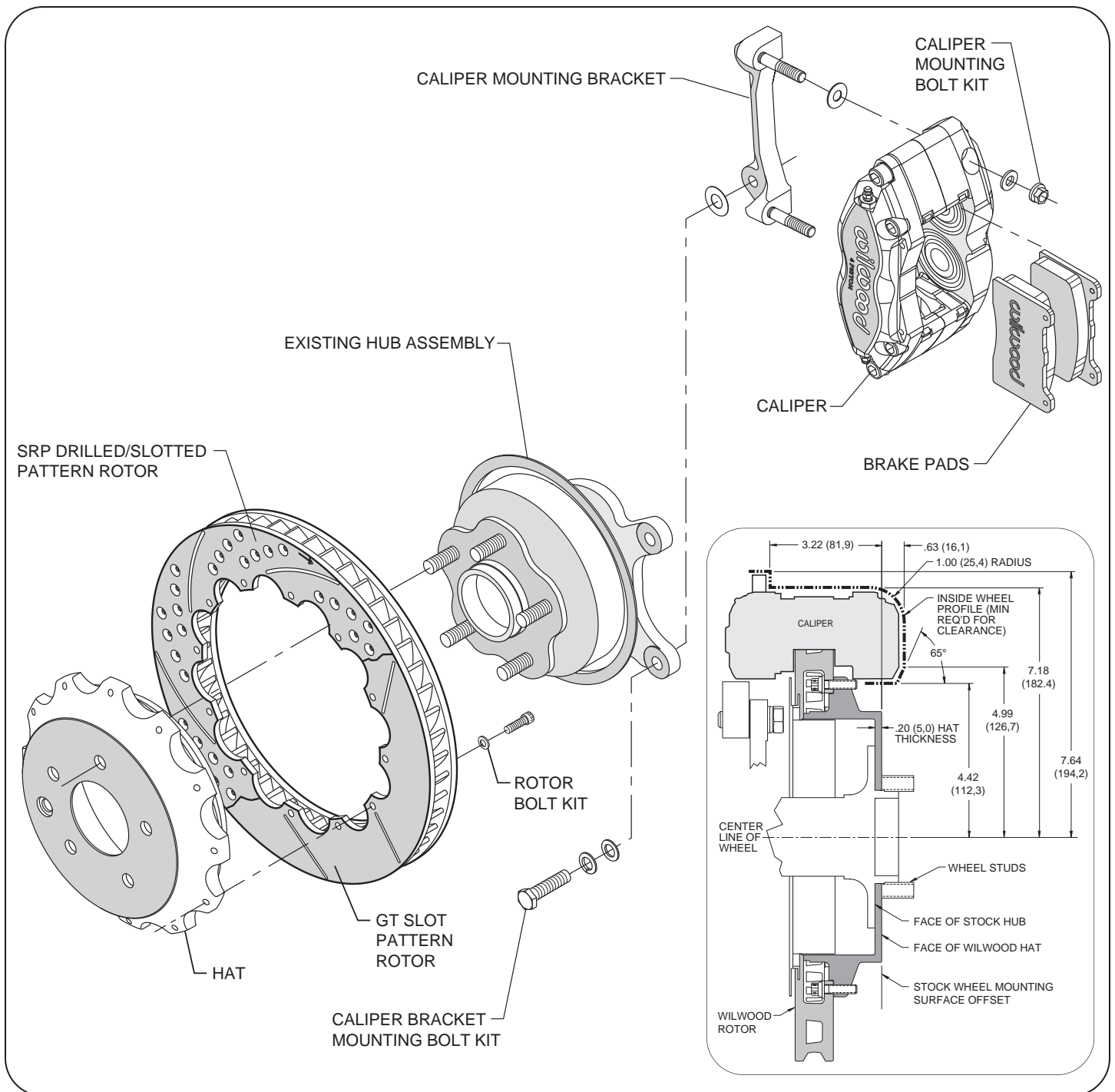

Typical Installation Diagram, Major Components Identified. Minimum Wheel Fit Dimensions Shown Inset

ORDERING INFORMATION: BRAKE AND FLEX LINE KITS:

MAKE / MODEL	YEAR	KIT PART NUMBERS		
		GT ROTOR KIT	SRP ROTOR KIT	FLEX LINE KITS
Nissan 350Z/370Z-Black Caliper	2003 - Present	140-9507	140-9507-D	220-9197
Infiniti G35/G37-Black Caliper	2003 - Present	140-9507	140-9507-D	220-9197
Nissan 350Z/370Z-Red Caliper	2003 - Present	140-9507-R	140-9507-DR	220-9197
Infiniti G35/G37-Red Caliper	2003 - Present	140-9507-R	140-9507-DR	220-9197