

“SMART PAD” BP-30 COMPOUND

BP-30 Compound

Heat Range: Medium - X-High
 Cold Torque: Medium-High
 Hot Torque: High
 Wear Rate: Low

General Characteristics / Popular Applications:

- Baseline pad for asphalt late models, modifieds, and sprints
- Severe duty, hard braking dirt track applications
- Intermediate duty road racing, auto-cross, and rally
- Positive, predictable response throughout full temperature range
- Compatible with all iron, steel, and titanium rotors



BP-30 compound "Smart Pads" represent the newest technology for high torque, high temperature race friction. This newly developed material exhibits the combined qualities of attributes found in "soft" driving pads with the high temperature torque and fade resistance necessary for hard braking in competition. BP-30 exhibits excellent modulation qualities, a clean release, and consistent response throughout its entire effective temperature range. It's accomplished without the harsh rotor abrasion normally associated with high carbon metallic based compounds and beds quickly to new rotors.

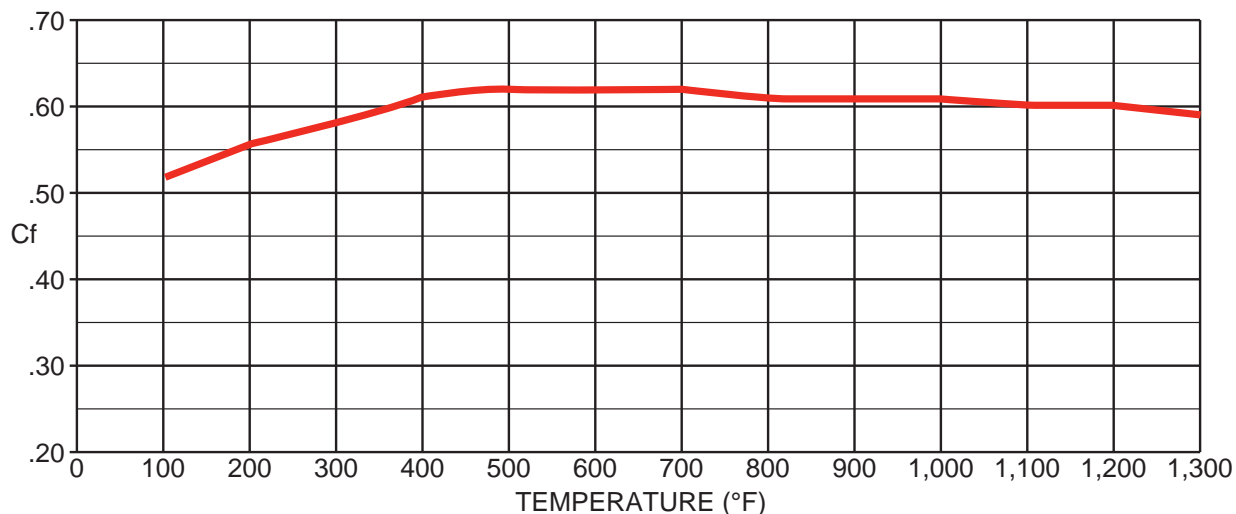

Ordering Information:

| PAD TYPE | CALIPER | BP-30 P/N | INTERCHANGE |
|----------|--|-----------|-------------------------|
| 6617 | W6A / W4A | 150-9980K | None |
| 6812 | DynaPro Single | 150-9862K | R20-12, 7757/12, HB104 |
| 7112 | Dynalite w/Cotter Pin / DL | 150-9863K | R302-12, 7752/12, HB100 |
| 7420 | Superlite w/Bridgebolt, FSL, SL4, SL6 - 20mm | 150-9864K | R701-20 |
| 7816* | DynaPro, NDL | 150-9865K | R303-16 |
| D52 | GM II, GM III, GM Full Size | 150-9866K | D52, 052/14, HB103 |

*Replaces pad type 7216

Pad part numbers are for an axle set. Please reference the reverse side for pad diagrams and dimensional characteristics.

Pad 6617 - W6A / W4A

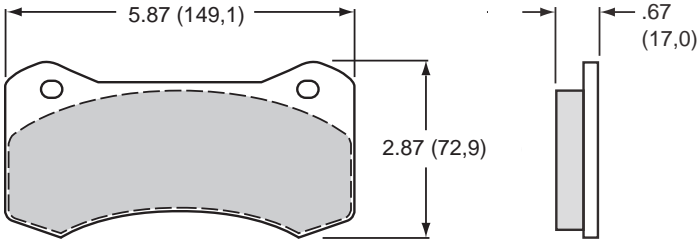

Pad 6812 - Dynalite Single / DLS

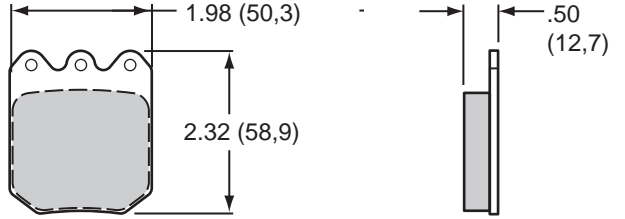

Pad 7112 - Dynalite w/Cotter Pin / DL

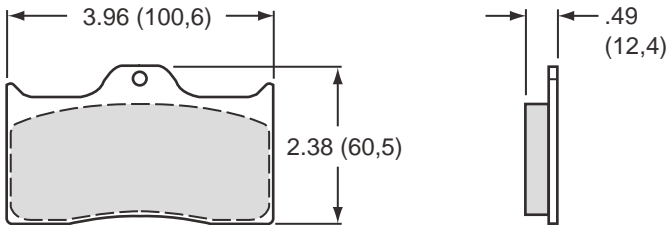

Pad 7420 - Superlite w/Bridgebolt / FSL, SL4, SL6

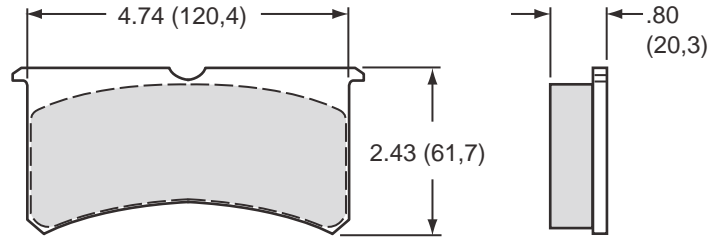

Pad 7816 - DynaPro / NDL

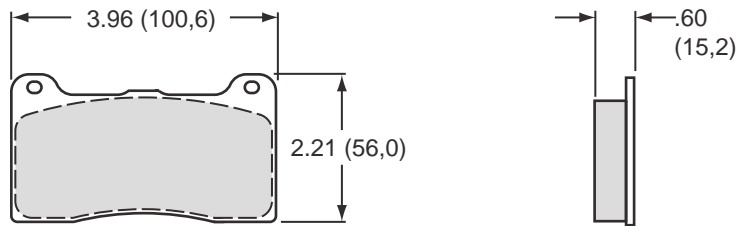

Pad D52 - GM II, GM III, GM Full Size

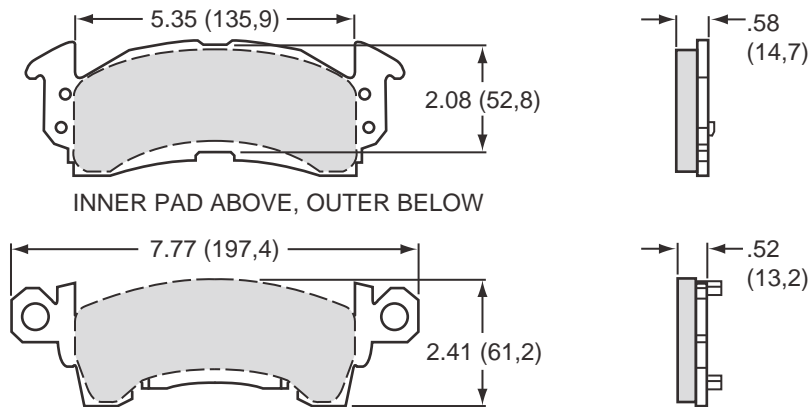

Need additional information - fast? Utilizing your Smartphone, scan the image at the left to jump to our web site. This code takes you to our home page and social media sites where information is just a click away, [or click here.](#)