

DYNALITE PRO SERIES FRONT HUB KIT FOR 1941 - 1955 BUICK

Models Covered:

- General Motors Buick, 1941 - 1956 model years

Kit Features:

- Offers a restored appearance while providing the enhanced stopping ability of disc brakes for driving safety.
- High quality lightweight conversion kit is designed to bolt on directly to the stock spindle without any modifications.
- Upgrade from OE calipers to billet forged four piston Dynalite calipers available in black anodized durable coat finish.
- 11.88" diameter ULHP plain face rotors.
- Optional DOT approved stainless steel flexline kit available specifically for this installation.
- Fully compatible with original equipment master cylinder output.
- BP-10 street performance brake pads standard.



Front Kit Assembly

Component Features:

Forged Billet Dynalite Lug Mount Calipers

- Calipers provide big clamping power in a truly lightweight, rigid and reliable design.
- Four stainless steel pistons provide additional corrosion resistance and the lowest heat transfer of any one-piece piston design.
- Black anodized finish provides excellent corrosion resistance and long term preservation of their high-tech style and appearance.

ULHP Integrated Hub / Rotor

- Replacement rotors provide the highest degree of cooling efficiency with increased surface area and improved air circulation between the rotor faces.
- ULHP rotors provide high performance and rugged durability for a wide range of competition, performance, and sport driving applications. Rotors are cast from premium grade, long grain carbon iron.
- Hubs include bearing and seals.

Wilwood BP-10 "Smart Pads"

- All kits include BP-10 metallic-composite compound "Smart Pads". BP-10 delivers the increased friction; higher fade resistance, and longer wear of an entry-level track pad, with virtually noise and dust free performance for the street.
- Optional race-only compounds can be ordered to suit the braking requirements at all levels of severe duty and sustained high heat competition.

Hardware and Plumbing

- Installation is simple. The kit is a complete bolt-on without the need to modify any of the existing brake or suspension components. Aluminum mounting brackets and premium grade hardware are supplied with detailed installation instructions in every kit.
- Stainless steel braided competition flexline kits are required to connect the Wilwood calipers to the brake system and must be ordered separately. Order part number 220-12296.

WARNING
 INSTALLATION OF THIS KIT SHOULD **ONLY** BE PERFORMED BY PERSONS EXPERIENCED IN THE INSTALLATION AND PROPER OPERATION OF DISC BRAKE SYSTEMS.

NOTE
 SPECIFIC PARTS MAY VARY FROM DIAGRAM

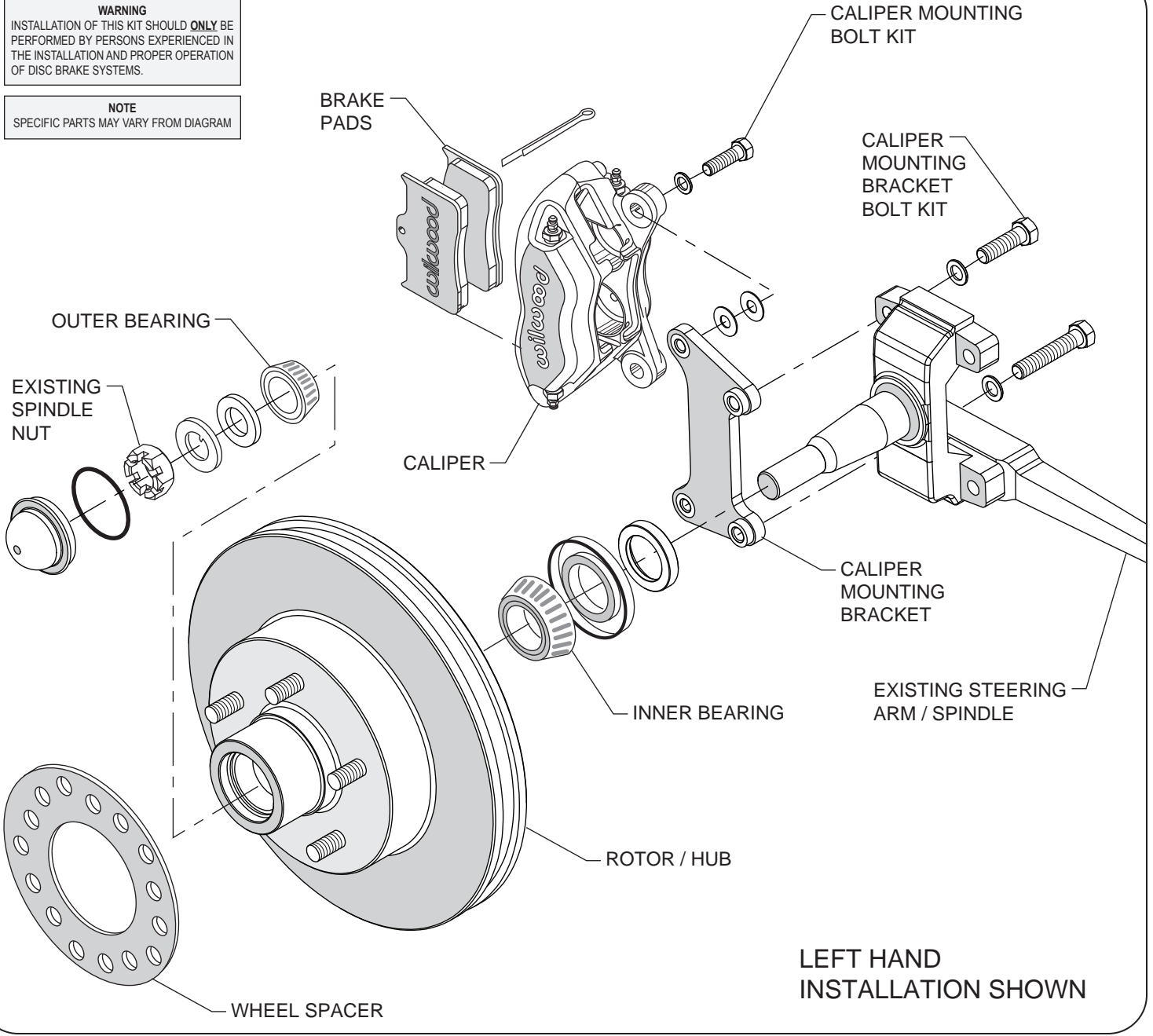

Typical Installation Diagram

ORDERING INFORMATION:

PART NUMBER

140-12321

DESCRIPTION

Front Kit, Buick, Dynalite Caliper, 11.88" ULHP Plain Face Rotor