

FORD MUSTANG DYNALITE DRAG RACE FRONT HUB BRAKE KIT

Models Covered:

Ford Mustang (Drum / Disc Spindle) 1970-1973

Kit Features:

- Black anodized forged Dynalite 4-piston calipers.
- CNC machined aluminum hubs.
- BP-10 performance brake pads standard.
- Optional DOT approved stainless steel flexline kit available in various lengths for a custom installation.
- Compatible with OE master cylinder output.
- Requires minor spindle modifications for caliper mounting bracket (disc brake applications only).

Component Features:

Forged Billet Dynalite Four Piston Calipers

- **Calipers** provide big clamping power in a truly lightweight, rigid and reliable design.
- Four stainless steel pistons generate high clamping force and balanced pad loading with low heat transfer and high resistance to corrosion.
- Spring loaded stainless steel SRS bridge plates reduce noise by damping engagement harmonics and stopping pad rattle. Bridge wear caused by gouging at the pad trailing edge is also eliminated.
- Internal fluid passages prevent all potential problems associated with external fluid transfer tubes.
- Four corner bleed screws accommodate effective gas evacuation regardless of mounting position.
- Top loaded pads are easily inspected and serviced without the need for caliper removal from the mount.

High Strength Alloy Steel 11.75" Diameter Rotors

- Increased diameter multiplies brake torque to reduce stopping distances over stock diameter rotors.
- Choice of 5.9 pound **solid plate** or 5.3 pound **drilled plate** rotors provide quicker acceleration for improved ET's by substantially reducing the rotating weight in the driveline.
- Premium grade, high strength, lightweight steel alloy provides outstanding thermal stability during sharp rises in rotor temperatures on hard stops.

Forged Billet Performance Hubs

- Forged billet **hubs** are made from premium grade alloy billets that are forged into shape under high heat and pressure, the CNC machined for a precise fit on the spindle.
- Hubs include installed bearing races and screw-on aluminum dust caps.

Wilwood BP-10 "Smart Pads"

- All kits include **BP-10** metallic-composite compound "Smart Pads". BP-10 delivers the increased friction; higher fade resistance, and longer wear of an entry-level track pad, with virtually noise and dust free performance for the street.
- Optional race-only compounds can be ordered to suit the braking requirements at all levels of severe duty and sustained high heat competition.

Mounting Hardware and Plumbing

- CNC machined billet aluminum brackets with steel thread inserts provide lightweight, yet sturdy mounting of the Dynalite caliper to the OE caliper mount bosses.
- Premium grade fasteners, washers, and alignment shims are included to complete each installation.
- Optional flex line kits include stainless steel reinforced hoses with machine crimped ends and the fittings necessary to connect the calipers with the OE brake line fitting at the chassis. Flex line kits must be ordered separately.



Download a high resolution photo for printing, [click here](#)

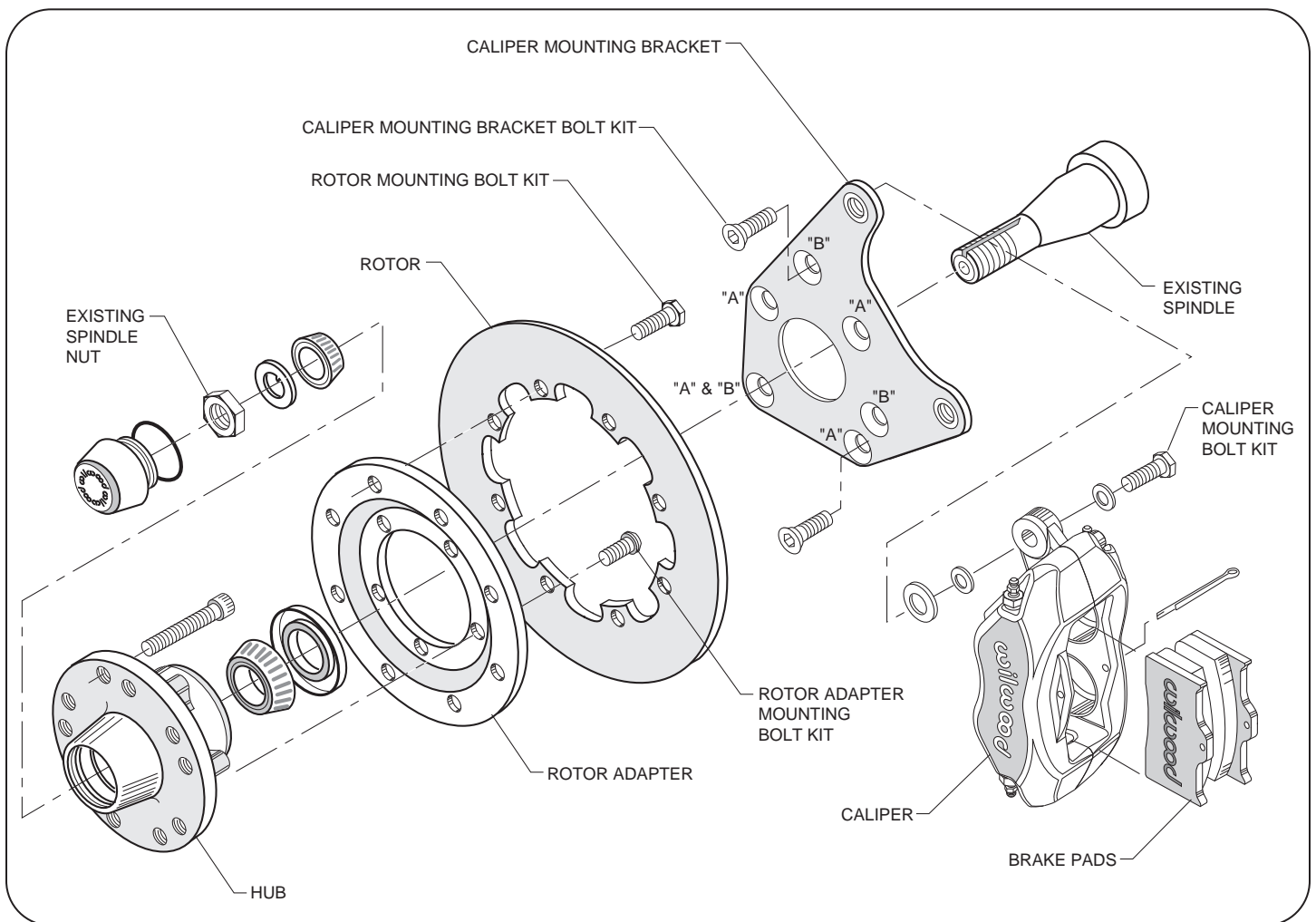

Typical Installation Diagram, Major Components Identified.

ORDERING INFORMATION:

PART NUMBER

140-11930

140-11930-D

DESCRIPTION

Front Kit, 1970-73 Ford Mustang, Dynalite Caliper, 11.75" Diameter Solid Rotor

Front Kit, 1970-73 Ford Mustang, Dynalite Caliper, 11.75" Diameter Drilled Rotor



Need additional information - fast? Utilizing your Smartphone, scan the image at the left to jump to our web site. This code takes you to our home page and social media sites where information is just a click away, [or click here.](#)