

FRONT FNSSL6R BIG BRAKE KITS FOR 2013 FORD FOCUS ST

Models Covered:

- 2013 Ford Focus ST

Kit Features:

- Upgrade from OE calipers to Forged Billet Narrow Superlite 6R six piston calipers for either street or track.
- Choose either 12.88" or 14.00" diameter GT slotted or SRP drilled and slotted rotors.
- Simple bolt-on installation with no modifications required.
- Fully compatible with ABS and OE master cylinder output.
- Wilwood always recommends checking their website, www.wilwood.com, for complete year/make/model application data and specific wheel clearance requirements.

Component Features:

FNSSL6R Radial Mount Six-Piston Calipers

- Competition proven forged billet bodies demonstrates superior strength and resistance to deflection and separation under high load.
- Differential bore stainless steel pistons generate high clamping force and balanced pad loading for optimized stopping power and even pad wear. Stainless pistons stay corrosion resistant and inhibit heat transfer from the pads to the caliper body, fluid and seals.
- The internal piston seal-in-bore design adds proven durability with keeping the fluid in and dirt out without the need for external boot seals.
- For more aggressive race applications, calipers can be fitted with our exclusive Thermlock pistons which provide the most effective thermal barrier for minimizing heat transfer from the brake pads to the caliper body, seals, and fluid.
- Spring loaded stainless SRS bridge plates dampen pad noise and protect the caliper bridges from wear.
- Calipers provide easy access to the pads for service, without the need to unbolt the calipers from their mounts.
- Standard part number kits are available with either black or red gloss powder coated calipers.

GT or SRP Series 12.88" x 1.10" / 14.00" x 1.10" Rotor Options

- GT competition series rotors feature full detail machining with asymmetrical slots in the faces. GT rotors provide the highest degree of durability and longer life for repeated hard braking and high temperature use.
- Drilled rotor kits feature our signature SRP performance drilled and slotted rotors with a durable e-coat finish. E-coat seals the casting and prevents corrosion in all areas of the rotor not swept clean by the brake pads. This durable finish will maintain the high tech styling and appearance of the rotors inside your wheels for many miles down the road.

Forged Aluminum GT Mounting Hats

- Forged aluminum rotor mount hats help reduce weight with the strength to handle the exceptional brake torque delivered by the FNSSL6R calipers.
- Black E-coat finish resists corrosion while adding to the aggressive competition look inside the wheel.

Wilwood "Smart Pads"

- FNSSL6R kits include our proven formula BP-10 Smart Pads. BP-10 is a unique composite-metallic compound that provides increased friction, stopping power, and higher fade resistance in a clean and quiet running low dust style pad.
- Optional high-temp and race only pad compounds are also available.

Radial Mounting Brackets, Hardware and Plumbing

- Radial mounting provides secure attachment directly to the OE mounts, with two planes of adjustment for precise alignment of the caliper over the rotor. Brackets, premium grade fasteners and alignment shims are included in each kit.
- Jacketed stainless steel braided, DOT approved flexline kits are included with each brake kit.



FNSSL6R Kit Assembly, 12.88" Shown

Download High Resolution Photo,
[Click Here](#)

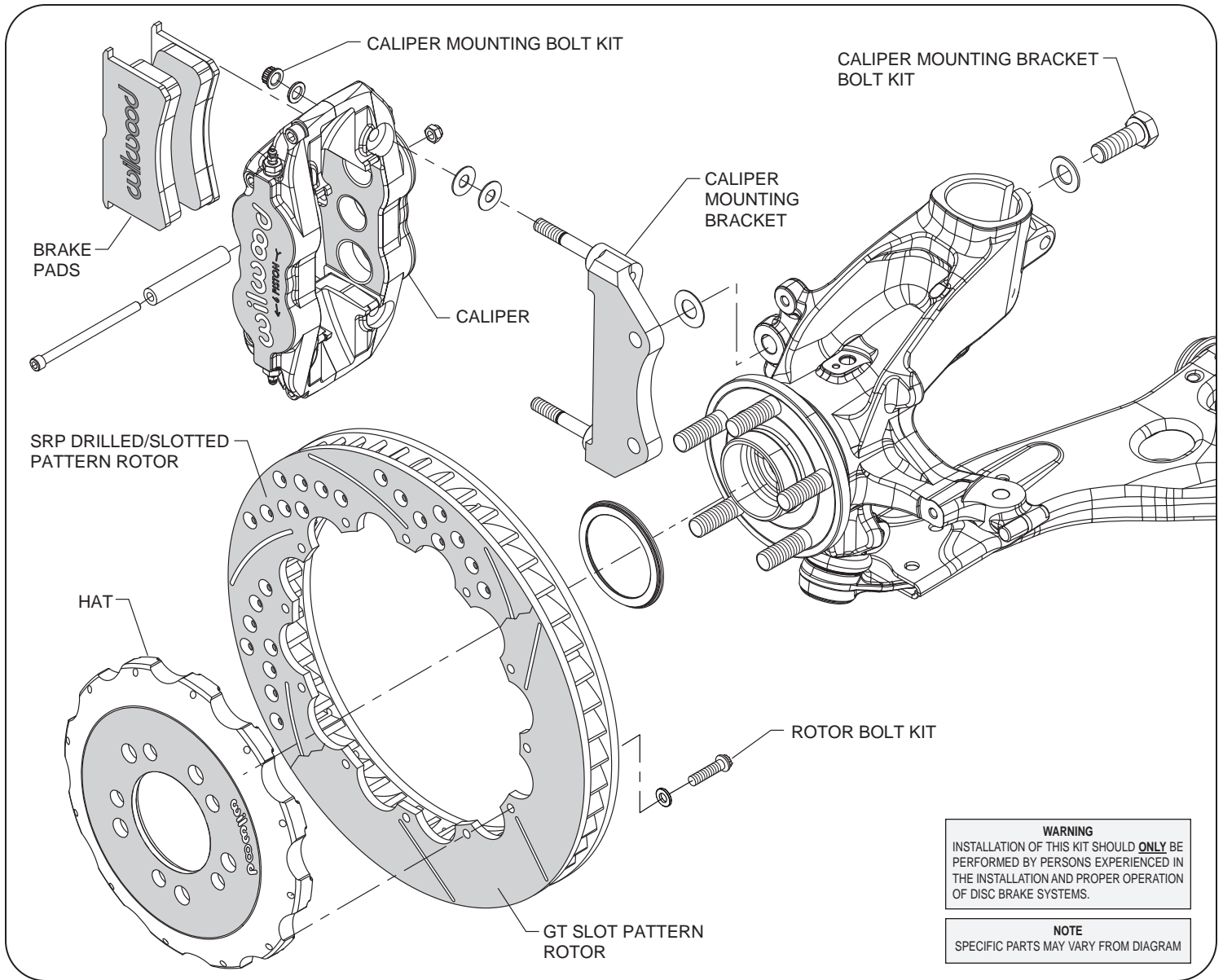

Typical Installation Diagram (12.88" Kit Shown)

ORDERING INFORMATION:

PART NUMBER

DESCRIPTION

140-13018	Front Kit, Ford Focus ST, FNSL6R Caliper, 12.88" GT Rotor, Black Caliper
140-13018-D	Front Kit, Ford Focus ST, FNSL6R Caliper, 12.88" SRP Drilled and Slotted Rotor, Black Caliper
140-13018-R	Front Kit, Ford Focus ST, FNSL6R Caliper, 12.88" GT Rotor, Red Caliper
140-13018-DR	Front Kit, Ford Focus ST, FNSL6R Caliper, 12.88" SRP Drilled and Slotted Rotor, Red Caliper
140-13019	Front Kit, Ford Focus ST, FNSL6R Caliper, 14.00" GT Rotor, Black Caliper
140-13019-D	Front Kit, Ford Focus ST, FNSL6R Caliper, 14.00" SRP Drilled and Slotted Rotor, Black Caliper
140-13019-R	Front Kit, Ford Focus ST, FNSL6R Caliper, 14.00" GT Rotor, Red Caliper
140-13019-DR	Front Kit, Ford Focus ST, FNSL6R Caliper, 14.00" SRP Drilled and Slotted Rotor, Red Caliper



Need additional information - fast? Utilizing your Smartphone, scan the image at the left to jump to our web site. This code takes you to our home page and social media sites where information is just a click away, [or click here.](#)