

Wilwood rear disc conversion kits, with internal shoe parking brakes, combine cutting edge brake technology and contemporary styling to provide a complete bolt-on street and track ready solution for these popular muscle car rear axles

## Kit Features:

- Direct bolt-on installation on 10-Bolt non C-Clip rear ends with 2.750" bearings
- Fits most 14" wheels
- Precision machined rotors
- Forged billet aluminum calipers
- Internal drum style parking brake
- BP-10 Metallic Composite Smart Pads
- Virtually noise and dust free street performance
- Jacketed, stainless steel braided DOT approved flexlines



**Dynalite**  
**Rear Brake Kit**  
Shown with Red Caliper  
and SRP Rotor

plain face also available

**DynaPro**  
**Rear Brake Kit**  
Shown with Red Caliper  
and SRP Rotor

plain face also available

## Component Features:

 Made in USA

### Calipers

- DynaPro Low-Profile, or Dynalite 4-piston calipers
- Stainless Steel pistons for corrosion resistance and reduced heat transfer to fluid and seals
- Superior clamping power in a truly lightweight, rigid and reliable design
- Black anodized or red powder coat finishes

### Rotors (11.00" or 12.19" diameter)

- Vented plain-face rotors provide high performance and rugged durability
- Drilled and slotted rotors come standard with a durable e-coat finish
- Superior thermal stability and improved fatigue resistance
- Integrated rotor/hat accepts 5 x 4.50/4.75/5.00" wheel stud patterns

### Parking Brake

- Internal drum style
- Outstanding holding power in a compact, uncluttered package
- Mechanically actuated and spring loaded for quiet non-rattling performance

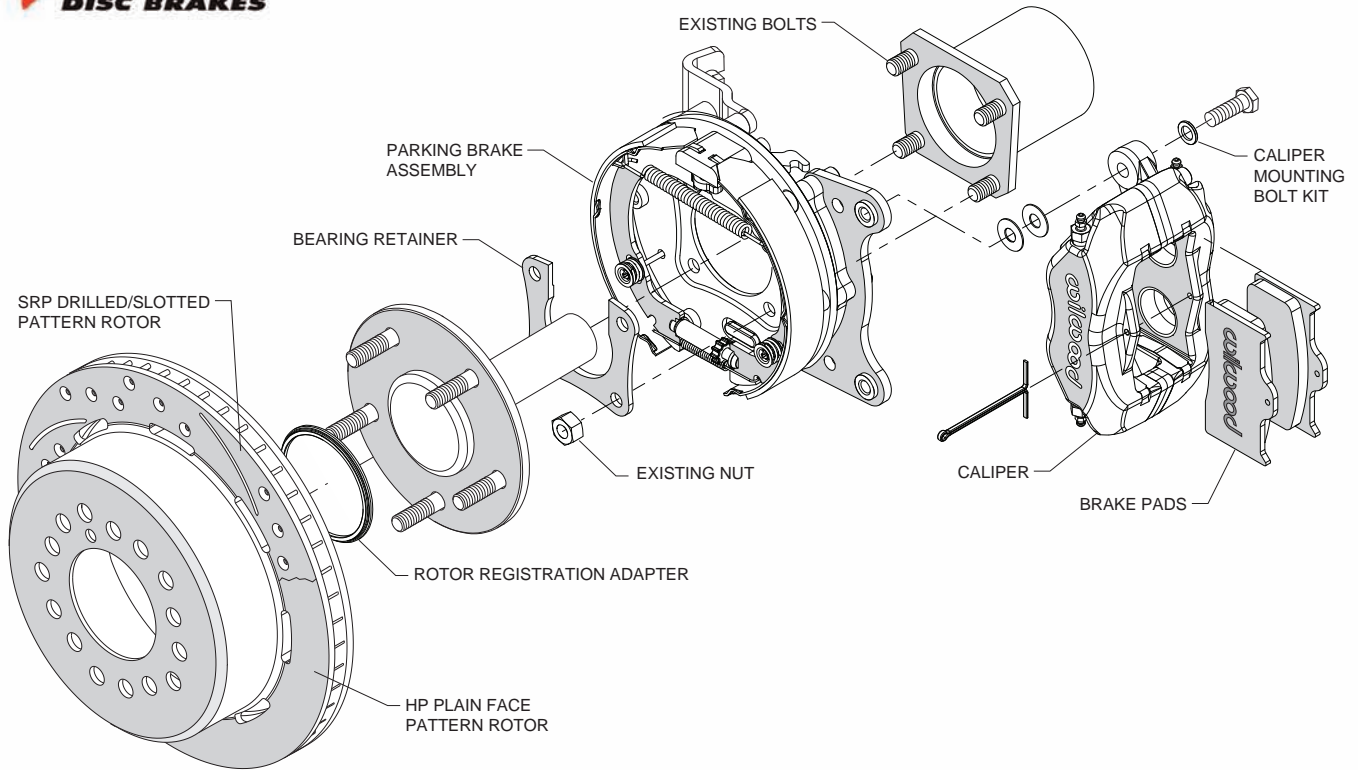

**Typical Installation Diagram, Dynalite 12.19" Kit Shown**

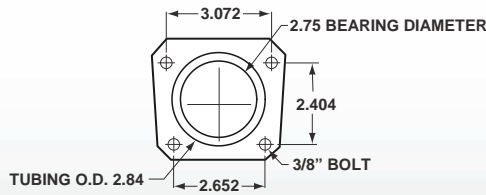

**1964-1970 BUICK • OLDS • PONTIAC W/2.75 BEARING**

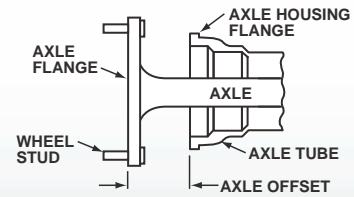

**AXLE FLANGE CROSS-SECTION**

**Buick • Olds • Pontiac Housing Flange / Axle Offset**

**PLEASE CHECK:** WILWOOD ALWAYS RECOMMENDS CHECKING THEIR WEBSITE, [www.wilwood.com](http://www.wilwood.com) FOR COMPLETE YEAR/MAKE/MODEL APPLICATION DATA AND SPECIFIC WHEEL CLEARANCE REQUIREMENTS.

**ORDERING INFORMATION:**

| PART NUMBER         | DESCRIPTION  |
|---------------------|--|
| <b>140-13513</b>    | Rear Parking Brake Kit, 2.75" Offset, DynaPro Low-Profile Caliper, 11.00" ULHP Rotor, Black Caliper                    |
| <b>140-13513-D</b>  | Rear Parking Brake Kit, 2.75" Offset, DynaPro Low-Profile Caliper, 11.00" SRP Drilled and Slotted Rotor, Black Caliper |
| <b>140-13513-DR</b> | Rear Parking Brake Kit, 2.75" Offset, DynaPro Low-Profile Caliper, 11.00" SRP Drilled and Slotted Rotor, Red Caliper   |
| <b>140-13513-R</b>  | Rear Parking Brake Kit, 2.75" Offset, DynaPro Low-Profile Caliper, 11.00" ULHP Rotor, Red Caliper                      |
| <b>140-13511</b>    | Rear Parking Brake Kit, 2.75" Offset, Forged Dynalite Caliper, 12.19" ULHP Rotor, Black Caliper                        |
| <b>140-13511-D</b>  | Rear Parking Brake Kit, 2.75" Offset, Forged Dynalite Caliper, 12.19" SRP Drilled and Slotted Rotor, Black Caliper     |
| <b>140-13511-DR</b> | Rear Parking Brake Kit, 2.75" Offset, Forged Dynalite Caliper, 12.19" SRP Drilled and Slotted Rotor, Red Caliper       |
| <b>140-13511-R</b>  | Rear Parking Brake Kit, 2.75" Offset, Forged Dynalite Caliper, 12.19" ULHP Rotor, Red Caliper                          |