



# GM D154 METRIC FORGED LIGHTWEIGHT RACING CALIPER



## **Wilwood GM D154 Metric**

*lightweight forged*

*aluminum racing calipers combine*

*advanced computer modeling design, stress flow forging technology, and four decades of championship brake system know-how to provide this ultra-high strength lightweight racing caliper.*

## **Caliper Features**



- Forged aluminum black anodized body with stainless steel piston
- Choice of 2.50" or 2.00" pistons covering rotors from .81" to 1.04" thickness up to 12.19" diameter
- Fluid inlet port centered directly behind the piston eliminates any interference with slide pins
- Lower deflection rate and higher volumetric efficiency than all competitor's heavier cast models
- 2.50" piston model weighs only 3.3 pounds
- Uses standard metric D154 pads, mounting height, and offset

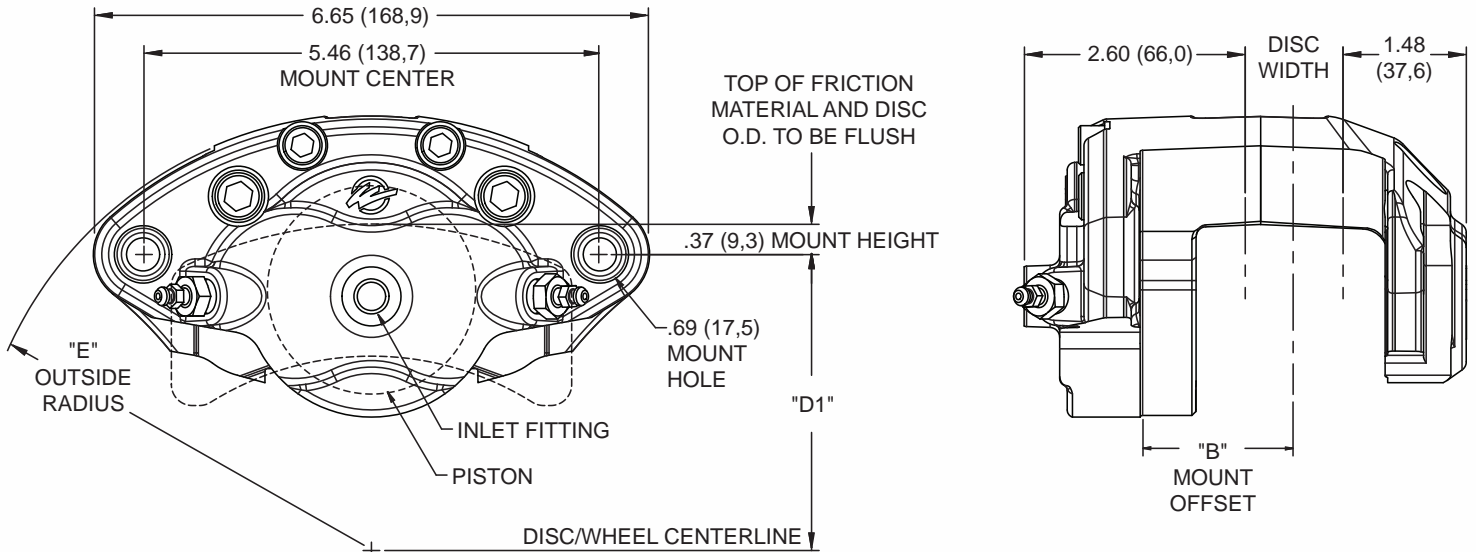

DIMENSION "D1" = (DISC DIAMETER/2) - .37 (9,3)  
CALIPER MOVES INWARD AS PAD WEARS, .38 (9,5) MAX.  
INLET FITTING: 1/8-27 NPT

THIS CALIPER IS A DIRECT REPLACEMENT FOR FACTORY CALIPERS USING THE D154 TYPE BRAKE PAD.

DISC WIDTH	"B" MOUNT OFFSET
1.04 (26,4)	1.80 (45,8)

DISC DIAMETER	"E" OUTSIDE RADIUS
11.00 (279,4)	6.82 (173,2)
11.75 (298,5)	7.19 (182,6)
11.88 (301,8)	7.26 (184,4)
12.19 (319,6)	7.41 (188,2)

### GM Metric Caliper, Dimensional Characteristics

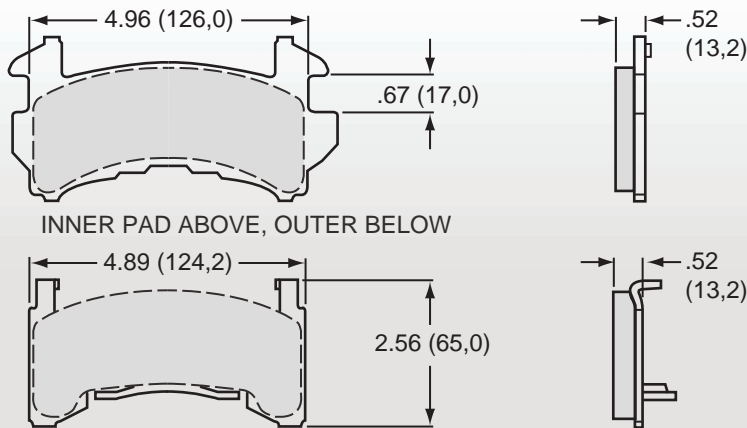

AXLE SET P/N	PAD TYPE / COMPOUND
15A - 6219K	D154 A PolyMatrix
15B - 3998K	D154 B PolyMatrix
15C - 4420K	D154 C PolyMatrix
15E - 6103K	D154 E PolyMatrix
15Q - 6831K	D154 Q PolyMatrix
150 - 8936K	D154 10 BP-10 Smart Pad
150 - 9422K	D154 20 BP-20 Smart Pad
150 - 11737K	D154 30 BP-30 Smart Pad
150 - 12250K	D154 40 BP-40 Smart Pad
150 - D0154K	D154 PM ProMatrix

### GM Metric Caliper, Type D154 Brake Pad Dimensions and Ordering Information

#### ORDERING INFORMATION:

CALIPER	PISTON SIZE	ROTOR WIDTH	BLACK ANODIZED PART NUMBER
GM Metric	2.50"	.81" - 1.04"	<a href="#">120-13900</a>
GM Metric	2.00"	.81" - 1.04"	<a href="#">120-13899</a>