



CAMARO / FIREBIRD • 1998-2002 SUPERLITE 4R/ST ROAD RACE BRAKE KITS

Superlite Quick-Silver 4R/ST race kits combine race proven technology with precision design to deliver high performance response and durability in extreme on-track competition for all 1998 to 2002 models, and all 1993 to 1997 cars that have been upgraded with 1998 to 2002 model spindles.



Kit Features



- Forged aluminum Superlite 4R/ST Quick-Silver four piston calipers with Thermlock® pistons
- 13.06" x 1.25" **Spec 37** alloy directional vane two-piece rotors with smooth HD or slotted GT faces
- PolyMatrix "H" compound race pads
- Forged aluminum, weight saving rotor mounting hats
- Direct bolt radial mount caliper brackets and hardware
- Piston volume configured for full compatibility with OE power brake system and ABS
- Easily matched to common master cylinder sizes with manual balance bar brake pedals
- Stainless steel braided flexlines, DOT style reinforced ends and a protective outer jacket
- Simple bolt-on installation

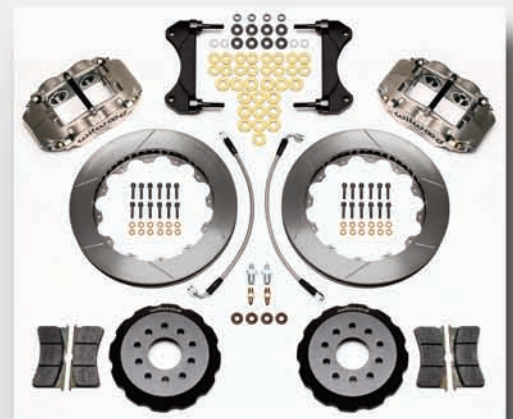
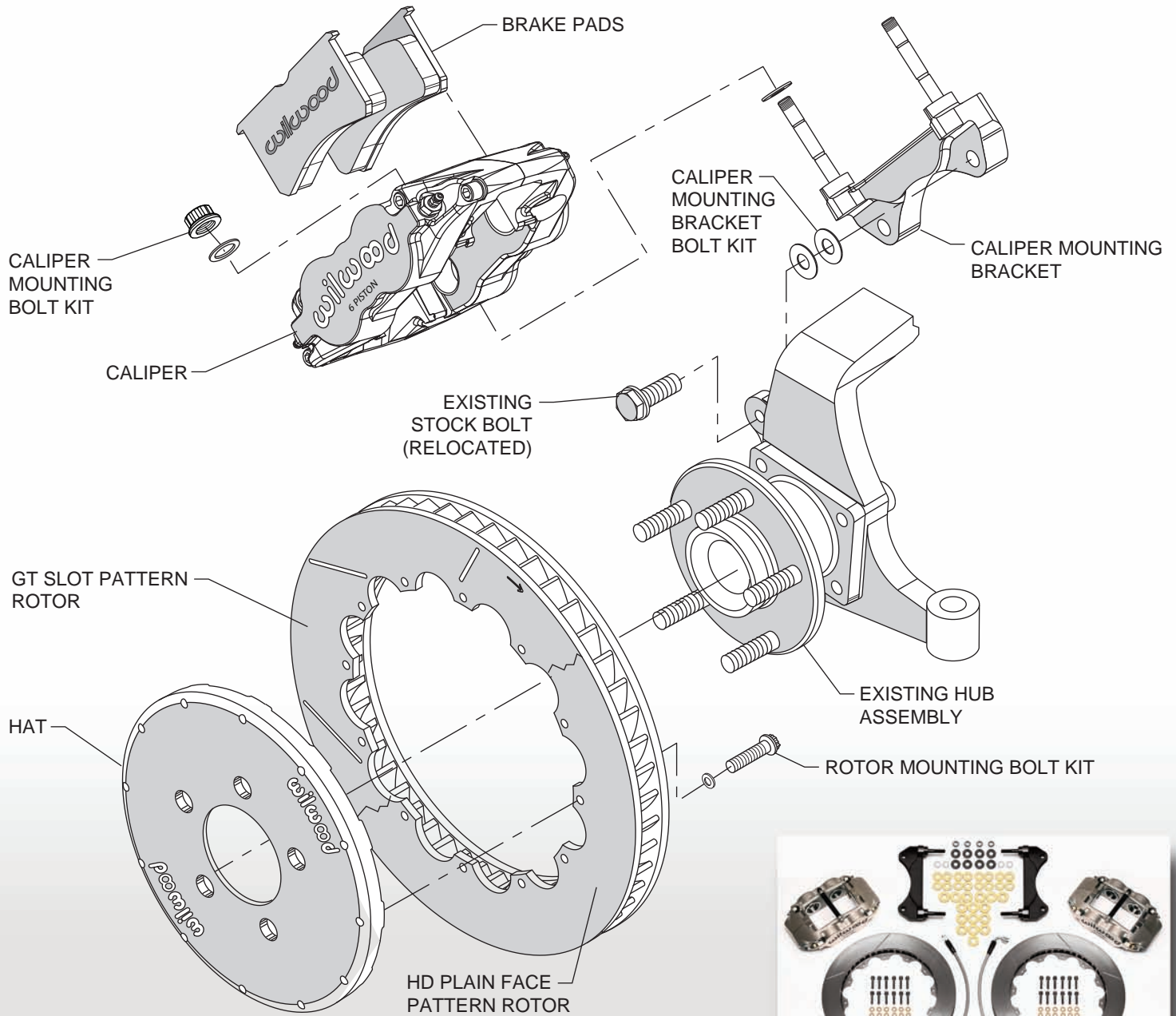

PLEASE CHECK: WILWOOD ALWAYS RECOMMENDS CHECKING www.wilwood.com FOR COMPLETE YEAR/MAKE/MODEL APPLICATION DATA AND SPECIFIC WHEEL CLEARANCE REQUIREMENTS.

ORDERING INFORMATION:

PART NUMBER	DESCRIPTION	ROTOR TYPE
140-14074-N	Superlite Quick-Silver 4R/ST Front Road Race Brake Kit, 1998-2002 Camaro/Firebird	GT Slot Face Rotor
140-14075-N	Superlite Quick-Silver 4R/ST Front Road Race Brake Kit, 1998-2002 Camaro/Firebird	HD Plain Face Rotor