

ASSEMBLY INSTRUCTIONS
FOR
SUPERLITE 6 BIG BRAKE FRONT HUB KIT
PRO STREET APPLICATION, 12.90" DIAMETER VENTED ROTOR

(1984-86 SVO) 1987-1993 MUSTANG (4 LUG, STOCK OFFSET)

PART NUMBER GROUP

140-6156

**DISC BRAKES SHOULD ONLY BE INSTALLED BY SOMEONE
EXPERIENCED AND COMPETENT IN THE INSTALLATION
AND MAINTENANCE OF DISC BRAKES**

READ ALL WARNINGS

WARNING

IT IS THE RESPONSIBILITY OF THE PERSON INSTALLING ANY BRAKE COMPONENT OR KIT TO DETERMINE THE SUITABILITY OF THE COMPONENT OR KIT FOR THAT PARTICULAR APPLICATION. IF YOU ARE NOT SURE HOW TO SAFELY USE THIS BRAKE COMPONENT OR KIT, YOU SHOULD NOT INSTALL OR USE IT. DO NOT ASSUME ANYTHING. IMPROPERLY INSTALLED OR MAINTAINED BRAKES ARE DANGEROUS. IF YOU ARE NOT SURE, GET HELP OR RETURN THE PRODUCT. YOU MAY OBTAIN ADDITIONAL INFORMATION AND TECHNICAL SUPPORT BY CALLING WILWOOD AT (805) 388-1188, OR VISIT OUR WEB SITE AT WWW.WILWOOD.COM. USE OF WILWOOD TECHNICAL SUPPORT DOES NOT GUARANTEE PROPER INSTALLATION. YOU, OR THE PERSON WHO DOES THE INSTALLATION MUST KNOW HOW TO PROPERLY USE THIS PRODUCT. IT IS NOT POSSIBLE OVER THE PHONE TO UNDERSTAND OR FORESEE ALL THE ISSUES THAT MIGHT ARISE IN YOUR INSTALLATION.

RACING EQUIPMENT AND BRAKES MUST BE MAINTAINED AND SHOULD BE CHECKED REGULARLY FOR FATIGUE, DAMAGE, AND WEAR.



WARNING

DO NOT OPERATE ANY VEHICLE ON UNTESTED BRAKES!
SEE MINIMUM TEST PROCEDURE WITHIN

ALWAYS UTILIZE SAFETY RESTRAINT SYSTEMS AND ALL OTHER AVAILABLE SAFETY EQUIPMENT WHILE OPERATING THE VEHICLE.

IMPORTANT • READ THE DISCLAIMER OF WARRANTY INCLUDED IN THE KIT.

NOTE: Some cleaners may stain or remove the finish on brake system components. Test the cleaner on a hidden portion of the component before general use.

Important Notice - Read This First

Before any tear-down or disassembly begins, review the following information:

- Installation of this kit requires spindle modifications that are best accomplished by a qualified machine shop. Please read installation instructions completely before beginning work.
- Review the wheel clearance diagram (figure 2, page 4) to verify that there is adequate clearance with the wheels you will be using with the installation. This kit will result in the wheels being moved out approximately 1/8" beyond the stock location.
- Front brake kits do not include flex lines. OEM brake lines will not adapt to Wilwood calipers. Check the assembly instructions, or associated components section for brake line recommendations before assembly. In addition, Wilwood offers an extensive listing of brake lines and fittings on our web site: www.wilwood.com.
- Due to OEM production differences and other variations from vehicle to vehicle, the fastener hardware and other components in this kit may not be suitable for a specific application or vehicle.
- It is the responsibility of the purchaser and installer of this kit to verify suitability / fitment of all components and ensure all fasteners and hardware achieve complete and proper engagement. Improper or inadequate engagement can lead to component failure.

Exploded Assembly Diagram and Parts List

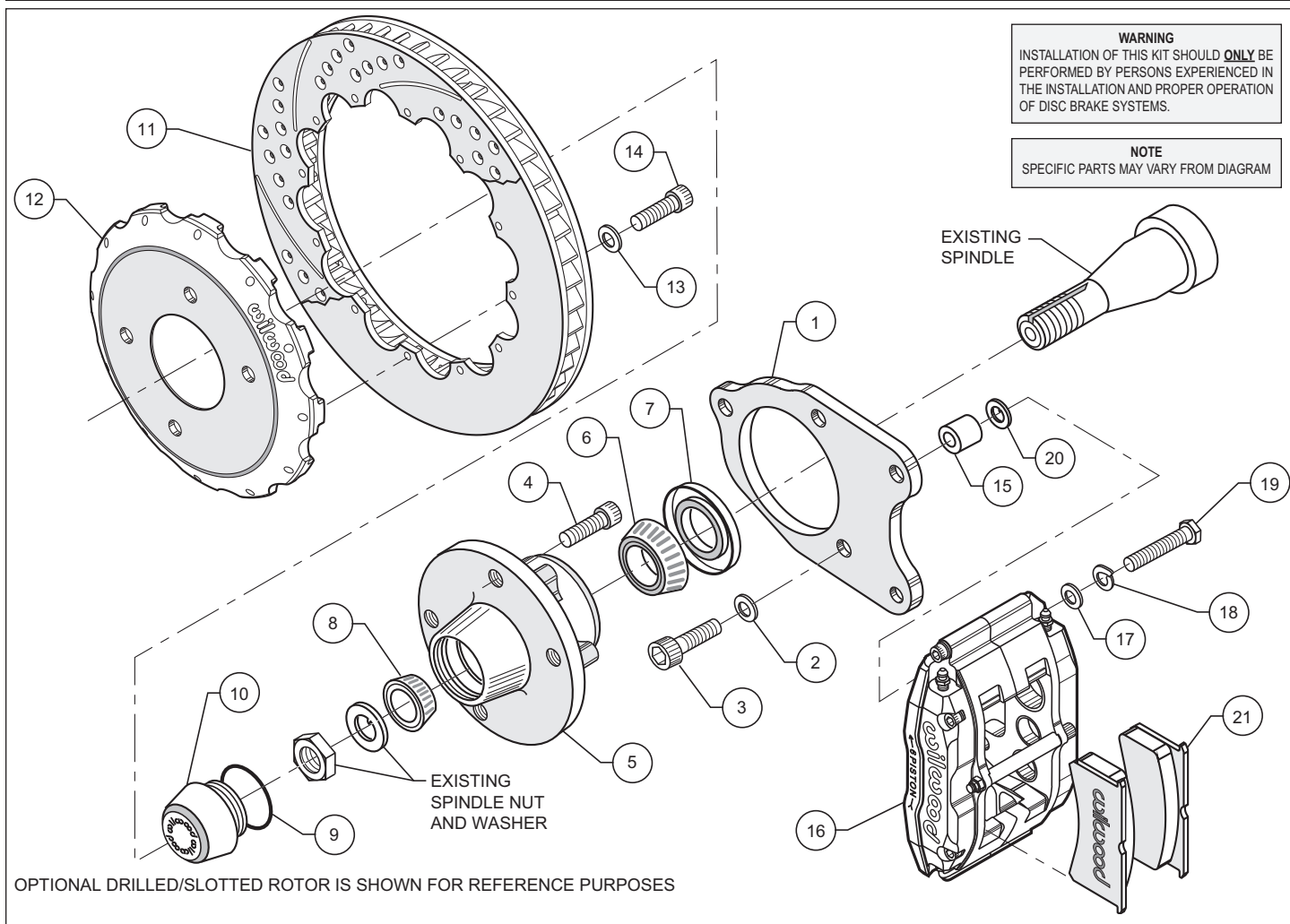

Figure 1. Typical Installation Configuration

Parts List

ITEM NO.	PART NO.	DESCRIPTION	QTY
1	250-6125	Bracket, Caliper Mounting	2
2	240-0140	Washer, 3/8 inch	6
3	230-1747	Bolt, 3/8-16 x 1.25 Long	6
4	230-0921	Stud, 1/2-20 x 3.00 Long, SHCS	10
5	270-3204	Hub Assembly	2
6	370-2609	Cone, Inner Bearing	2
7	380-2572	Seal, Grease	2
8	370-0882	Cone, Outer Bearing	2
9	211-1674	O-ring	2
10	270-3150	Cap, Dust	2
11	160-4564/65	Rotor, GT-48, 1.25" Thk x 12.90" Dia, 12 x 8.75" Bolt Circle	2
11A	160-7172/73	Rotor, SRP Drilled and Slotted	2
12	170-6157	Hat	2
13	240-2509	Washer, 1/2 inch	24
14	230-6737	Bolt, 1/4-20 x 1.00 Long, 12 PT CS	24
15	300-6160	Spacer, .722 Long	4
16	120-5960/61-RS	Caliper, Billet Superlite 6	2
17	240-0476	Washer, Flat, 7/16 inch	4
18	240-0139	Washer, Lock, 7/16 inch	4
19	230-2634	Bolt, 7/16-20 x 2.25 Long	4
20	240-4487	Shim, 0.032 inch Thick	16
21	150-8854K	Pad, BP-10 Compound, Axle Set	1

NOTES:

Part Number 230-4572 Rotor Bolt Kit, includes part numbers 230-6737 and 240-2509

Part Number 230-6225 Caliper Bracket Mounting Bolt Kit, includes P/N's 230-2634, 230-1747, 240-0139, 240-0140, 240-0476 & 240-4487

Item 11A is an optional item and included in the (D) kits. Add "-D" to end of part number when ordering.

General Information and Disassembly Instructions

Installation of this kit should **ONLY** be performed by persons experienced in the installation and proper operation of disc brake systems. Before assembling the Wilwood front disc brake kit, double check the following items to ensure a trouble-free installation.

- Make sure this is the correct kit to match the exact make and model year of the vehicles spindle (i.e., hubs for a 1970 Mustang spindle will not fit a 1987 Mustang spindle). On some models of disc brake spindles there are "ears" where the OEM calipers were mounted and these "ears" interfere with the assembly of the Wilwood disc brake kit. See spindle modification instructions below.
- Verify the hub stud pattern in this kit matches the stud pattern of the vehicles wheels.
- Verify your wheel clearance using Figure 3.
- Inspect the package contents against the parts list to ensure that all components and hardware are included.

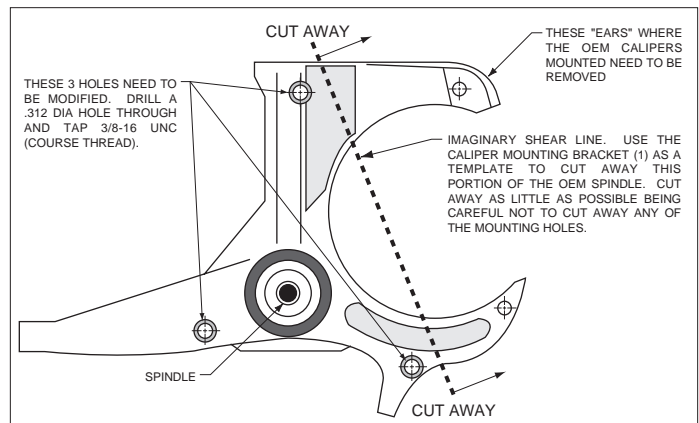

Figure 2. Typical Steering Arm / Spindle Modifications (your spindle may vary in looks from diagram)

Disassembly / Spindle Modifications

- Disassemble the original equipment front brakes:

Raise the front wheels off the ground. Support the front suspension by placing jack stands under the lower control arms. The lower control arms **MUST** be supported. The vehicle's weight must be on jack stands and not supported by a car jack or hoist.

Remove the center cap, cotter pin, nut lock and the wheel bearing nut and washer. Save the wheel bearing nut and nut lock. Remove the brake and hub assembly, including the wheel bearings. Disconnect the brake hoses from the brake line at the body. Remove the two upper spindle retaining nuts and bolts. Remove the lower ball joint to spindle nut and bolt. The backing plate, spindle and ball joint will now separate. Remove the spindle assembly.

- Clean and de-grease the spindles. Remove all nicks or burrs on the spindle snout and threads.

- The following spindle modifications should be performed by a qualified machinist. Refer to Figure 2 as necessary. Only one view of the steering arm/spindle is shown, but the modifications need to be performed on both steering arm/spindles.

- With the spindle positioned in its correct upright position with the snout pointing towards you, measure 2.875 inches from the spindle centerline to lower OEM caliper mounting ear, mark this point. Remove OEM caliper mounting ear from this mark, be careful not to cut into the dust plate mounting hole and raised boss. Remove all sharp corners and burrs with a file or grinder.

Disassembly (Continued) and Assembly Instructions

- Remove only the upper OEM caliper mounting ear making sure all the material required to mount the front strut is still intact. Remove all sharp corners and burrs with a file or grinder.

- Drill out the three dust plate mounting holes in the spindle face with a 5/16 inch (.312) diameter drill. Tap the three holes with a 3/8-16 UNC tap (these three holes will be used to mount the caliper mounting bracket). Verify that there are no raised burrs on the spindle face that may interfere with the assembly of the disc brake kit components.

Assembly Instructions (numbers in parenthesis refer to the part list/diagram on the preceding page): **CAUTION:** All mounting bolts must fully engage insert nuts. Be sure to check that all bolts are either flush or protruding through flanged side of insert nut after shimming.

- Apply red *Loctite*® 271 to bolt threads (3) before assembly of the caliper mounting bracket (1). Mount bracket (1) to dust face plate of spindle using washers (2) and bolts (3). Torque bolts (3) to 22 ft-lb. **NOTE:** Be sure the heads of the bracket (1) insert nuts are facing outward toward the wheel.

- Install wheel studs (4) into the hub (5). Torque to 77 ft-lb.

- Pack the large inner bearing cone (6) with high temperature disc brake bearing grease (available from your local auto parts store) and install into the backside of the hub (5). Install the grease seal (7) by pressing into the backside of the hub (5).

- Pack the small outer bearing cone (8) with high temperature disc brake bearing grease and install into front of hub (5). Slide the hub with outer bearing cone (8) onto the spindle. Secure using stock washer, adjusting nut and nut locking device. Adjust bearings per Original Equipment Manufacturer (OEM) specifications.

- Install the dust cap (10) onto the hub (5). Friction created by the o-ring (9) on the dust cap (10) keeps it from unscrewing. The O.D. of the existing spindle washer may be larger than the I.D. of the dust cap (10) not allowing it to seat against the hub face. Some grinding on the washer O.D. may be necessary to clear the I.D. of the dust cap (10).

- With the larger I.D. side of the rotor (11) facing away from the hat (12), bolt rotor (11) to hat (12) using washers (13) and bolts (14). Torque bolts (14) to 85 **in-lb**. Safety wire bolts (14) using standard 0.032 inch diameter stainless steel safety wire as shown in Figure 4. Please refer to Wilwood's data sheet DS-386 (available at www.wilwood.com/pdf/ds386.pdf) for complete safety wire installation instructions.

- NOTE:** Please reference the caution statement at the beginning of the assembly instructions. With the bleed screws pointing up, mount the caliper (16) onto the caliper bracket (1) with the flat washers (17), lock washers (18), bolts (19) and caliper spacer (15) positioned between caliper and bracket. Finger tighten. View the rotor (11) through the top opening of the caliper (16). The rotor (11) should be aligned in the center of the caliper (16). If not, adjust the caliper (16) by using 0.032 inch thick shims (20) placed between the caliper spacer (15) and the caliper (16). Finger tighten and recheck alignment. Apply red *Loctite*® 271 to bolt threads (19) and torque to 47 ft-lb. Safety wire caliper bolts (19).

- Remove the bridge bolt from the caliper (16) and install the disc brake pads (21). Reinstall the caliper bridge bolt.

- NOTE:** OEM rubber brake hoses generally cannot be adapted to Wilwood calipers. The caliper inlet fitting is a 1/8-27 NPT. The preferred method is to use steel adapter fittings at the caliper, either straight, 45 or 90 degree and enough steel braided line to allow for full suspension travel and turning radius, lock to lock. **Carefully route lines to prevent contact with moving suspension, brake or wheel components.** Wilwood hose kits are designed for use in many different vehicle applications and it is the installer's responsibility to properly route and ensure adequate clearance and retention for brake hose components. Wilwood offers a hose kit, P/N 220-6471, which includes hoses, fittings, etc., all in one package for this application.

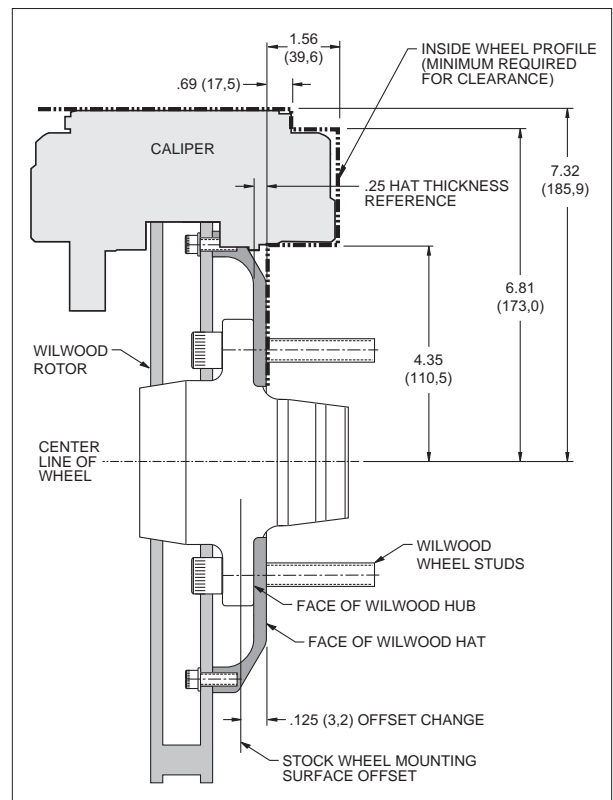

Figure 3. Wheel Clearance Diagram

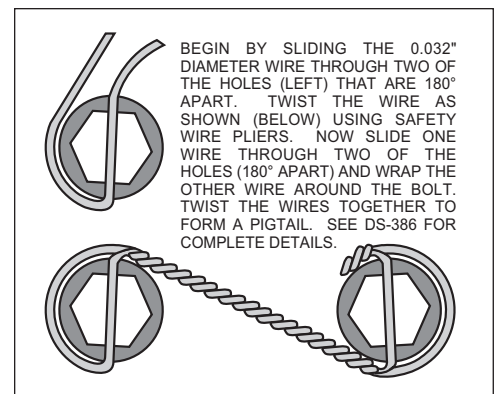

Figure 4. Safety Wire Diagram

Assembly Instructions (Continued)

- Specified brake hose kits may not work with all Years, Makes and Models of vehicle that this brake kit is applicable to, due to possible OEM manufacturing changes during a production vehicle's life. It is the installer's responsibility to ensure that all fittings and hoses are the correct size and length, to ensure proper sealing and that they will not be subject to crimping, strain and abrasion from vibration or interference with suspension components, brake rotor or wheel.
- In absence of specific instructions for brake line routing, the installer must use his best professional judgment on correct routing and retention of lines to ensure safe operation. Test vehicle brake system per the 'minimum test' procedure stated within this document before driving. After road testing, inspect for leaks and interference. Initially after install and testing, perform frequent checks of the vehicle brake system and lines before driving, to confirm that there is no undue wear or interference not apparent from the initial test. Afterwards, perform periodic inspections for function, leaks and wear in a interval relative to the usage of vehicle.
- Bleed the brake system. Reference the general information and recommendations below for proper bleeding instructions.

Additional Information and Recommendations

- Please read the following concerning balancing the brake bias on 4 wheel disc vehicles.

This brake kit can be operated using the stock OEM master cylinder. However, as with most suspension and tire modifications (from OEM specifications), changing the brakes may alter the front to rear brake bias. Rear brakes should not lock up before the front. Brake system evaluation and tests should be performed by persons experienced in the installation and proper operation of brake systems. Evaluation and tests should be performed under controlled conditions. Start by making several stops from low speeds then gradually work up to higher speeds. Always utilize safety restraint systems while operating vehicle.

Use a Wilwood adjustable proportioning valve if necessary to achieve proper brake balance, or

Use a Wilwood brake pedal/balancebar assembly with dual master cylinders (requires custom mounting as used in fabricated chassis race cars). A balance bar brake system permits incremental front to rear brake pressure adjustments.

- For optimum performance, fill and bleed the new system with Wilwood Hi-Temp^o 570 grade fluid or EXP 600 Plus. For severe braking or sustained high heat operation, use Wilwood EXP 600 Plus Racing Brake Fluid. Used fluid must be completely flushed from the system to prevent contamination. **NOTE:** Silicone DOT 5 brake fluid is **NOT** recommended.
- To properly bleed the brake system, begin with the caliper farthest from the master cylinder. Bleed the outboard bleed screw first, then the inboard. Repeat the procedure until all calipers in the system are bled, ending with the caliper closest to the master cylinder. **NOTE:** When using a new master cylinder, it is important to bench bleed the master cylinder first.
- If the master cylinder is mounted lower than the disc brake calipers, some fluid flowback to the master cylinder reservoir may occur, creating a vacuum effect that retracts the caliper pistons into the housing. This will cause the pedal to go to the floor on the first stroke until it has "pumped up" and moved all the pistons out against the pad again. A Wilwood in-line two pound residual pressure valve, installed near the master cylinder will stop the fluid flowback and keep the pedal firm and responsive.
- Test the brake pedal. It should be firm, not spongy and stop at least 1 inch from the floor under heavy load.
 - If the brake pedal is spongy, bleed the system again.
 - If the brake pedal is initially firm, but then sinks to the floor, check the system for fluid leaks. Correct the leaks (if applicable) and then bleed the system again.
 - If the brake pedal goes to the floor and continued bleeding of the system does not correct the problem, a master cylinder with increased capacity (larger bore diameter) will be required. Wilwood offers various lightweight master cylinders with large fluid displacement capacities.
- **NOTE:** With the installation of after market disc brakes, the wheel track may change depending on the application. Check your wheel offset before final assembly.
- On some models of disc brake spindles there are "ears" where the OEM calipers were mounted and these "ears" interfere with the assembly of the Wilwood disc brake kit. If it becomes necessary to remove these "ears", remove as little as possible being careful not to cut away any of the mounting holes that may be required to bolt on the caliper mounting bracket.
- If after following the instructions, you still have difficulty in assembling or bleeding your Wilwood disc brakes, consult your local chassis builder, or retailer where the kit was purchased for further assistance.

Brake Testing and Pad Bedding

WARNING • DO NOT DRIVE ON UNTESTED BRAKES BRAKES MUST BE TESTED AFTER INSTALLATION OR MAINTENANCE MINIMUM TEST PROCEDURE

- Make sure pedal is firm: Hold firm pressure on pedal for several minutes, it should remain in position without sinking. If pedal sinks toward floor, check system for fluid leaks. DO NOT drive vehicle if pedal does not stay firm or can be pushed to the floor with normal pressure.
- At very low speed (2-5 mph) apply brakes hard several times while turning steering from full left to full right, repeat several times. Remove the wheels and check that components are not touching, rubbing, or leaking.
- Carefully examine all brake components, brake lines, and fittings for leaks and interference.
- Make sure there is no interference with wheels or suspension components.
- Drive vehicle at low speed (15-20 mph) making moderate and hard stops. Brakes should feel normal and positive. Again check for leaks and interference.
- Always test vehicle in a safe place where there is no danger to (or from) other people or vehicles.
- Always wear seat belts and make use of all safety equipment.

PAD BEDDING PROCEDURE:

• Pump brakes at low speed to assure proper operation. On the race track, or other safe location, make a series of hard stops until some brake fade is experienced. Allow brakes to cool while driving at moderate speed to avoid use of the brakes. This process will properly burnish the brake pads, offering maximum performance.

Associated Components

<u>PART NO.</u>	<u>DESCRIPTION</u>
260-1874	Wilwood Residual Pressure Valve (2 lb for disc brakes)
260-1876	Wilwood Residual Pressure Valve (10 lb for drum brakes)
260-8419	Wilwood Proportioning Valve
290-0632	Wilwood Racing Brake Fluid (Hi-Temp° 570) (12 oz)
290-6209	Wilwood Racing Brake Fluid (EXP 600 Plus) (16.9 oz)
340-1285	Wilwood Floor Mount Brake Pedal (with balance bar)
340-1287	Wilwood Swing Mount Brake Pedal (with balance bar)
260-6764	Wilwood 3/4 inch High Volume Aluminum Master Cylinder
260-6765	Wilwood 7/8 inch High Volume Aluminum Master Cylinder
260-6766	Wilwood 1 inch High Volume Aluminum Master Cylinder
260-4893	1-1/16 inch Tandem Master Cylinder (aluminum housing)
250-2406	Mounting Bracket Kit (tandem master cylinder)
260-8555	Wilwood 1 inch Aluminum Tandem Chamber Master Cylinder
260-8556	Wilwood 1-1/8 inch Aluminum Tandem Chamber Master Cylinder
350-2038	1971 - 1973 Pinto Rack and Pinion (new, not rebuilt)
270-2016	Quick Release Steering Hub (3/4 inch shaft)
270-2017	Quick Release Steering Hub (5/8 inch shaft)
220-6471	Flex Line Kit, 1986-1993 Mustang