

ASSEMBLY INSTRUCTIONS
FOR
**DYNAPRO BIG BRAKE FRONT HAT KIT,
WITH 12.19" DIAMETER VENTED ROTOR**

2002 - PRESENT BMW MINI COOPER AND MINI COOPER"S"(1)

PART NUMBER GROUP

140-8528

**DISC BRAKES SHOULD ONLY BE INSTALLED BY SOMEONE
EXPERIENCED AND COMPETENT IN THE INSTALLATION
AND MAINTENANCE OF DISC BRAKES**

READ ALL WARNINGS

WARNING

IT IS THE RESPONSIBILITY OF THE PERSON INSTALLING ANY BRAKE COMPONENT OR KIT TO DETERMINE THE SUITABILITY OF THE COMPONENT OR KIT FOR THAT PARTICULAR APPLICATION. IF YOU ARE NOT SURE HOW TO SAFELY USE THIS BRAKE COMPONENT OR KIT, YOU SHOULD NOT INSTALL OR USE IT. DO NOT ASSUME ANYTHING. IMPROPERLY INSTALLED OR MAINTAINED BRAKES ARE DANGEROUS. IF YOU ARE NOT SURE, GET HELP OR RETURN THE PRODUCT. YOU MAY OBTAIN ADDITIONAL INFORMATION AND TECHNICAL SUPPORT BY CALLING WILWOOD AT (805) 388-1188, OR VISIT OUR WEB SITE AT WWW.WILWOOD.COM. USE OF WILWOOD TECHNICAL SUPPORT DOES NOT GUARANTEE PROPER INSTALLATION. YOU, OR THE PERSON WHO DOES THE INSTALLATION MUST KNOW HOW TO PROPERLY USE THIS PRODUCT. IT IS NOT POSSIBLE OVER THE PHONE TO UNDERSTAND OR FORESEE ALL THE ISSUES THAT MIGHT ARISE IN YOUR INSTALLATION.

RACING EQUIPMENT AND BRAKES MUST BE MAINTAINED AND SHOULD BE CHECKED REGULARLY FOR FATIGUE, DAMAGE, AND WEAR.



WARNING

**DO NOT OPERATE ANY VEHICLE ON UNTESTED BRAKES!
SEE MINIMUM TEST PROCEDURE WITHIN**

ALWAYS UTILIZE SAFETY RESTRAINT SYSTEMS AND ALL OTHER AVAILABLE SAFETY EQUIPMENT WHILE OPERATING THE VEHICLE.

IMPORTANT • READ THE DISCLAIMER OF WARRANTY INCLUDED IN THE KIT.

NOTE: Some cleaners may stain or remove the finish on brake system components. Test the cleaner on a hidden portion of the component before general use.

(1) IF UTILIZING THE STOCK 16" WHEELS, A 1/8" WHEEL SPACER WILL BE REQUIRED

Important Notice - Read This First

Before any tear-down or disassembly begins, review the following information:

- Review the wheel clearance diagram (figure 2, page 3) to verify that there is adequate clearance with the wheels you will be using with the installation.
- Front brake kits do not include flex lines. OEM brake lines will not adapt to Wilwood calipers. Check the assembly instructions, or associated components section for brake line recommendations before assembly. In addition, Wilwood offers an extensive listing of brake lines and fitting on our web site: www.wilwood.com.
- Due to OEM production differences and other variations from vehicle to vehicle, the fastener hardware and other components in this kit may not be suitable for a specific application or vehicle.
- It is the responsibility of the purchaser and installer of this kit to verify suitability / fitment of all components and ensure all fasteners and hardware achieve complete and proper engagement. Improper or inadequate engagement can lead to component failure.

Exploded Assembly Diagram

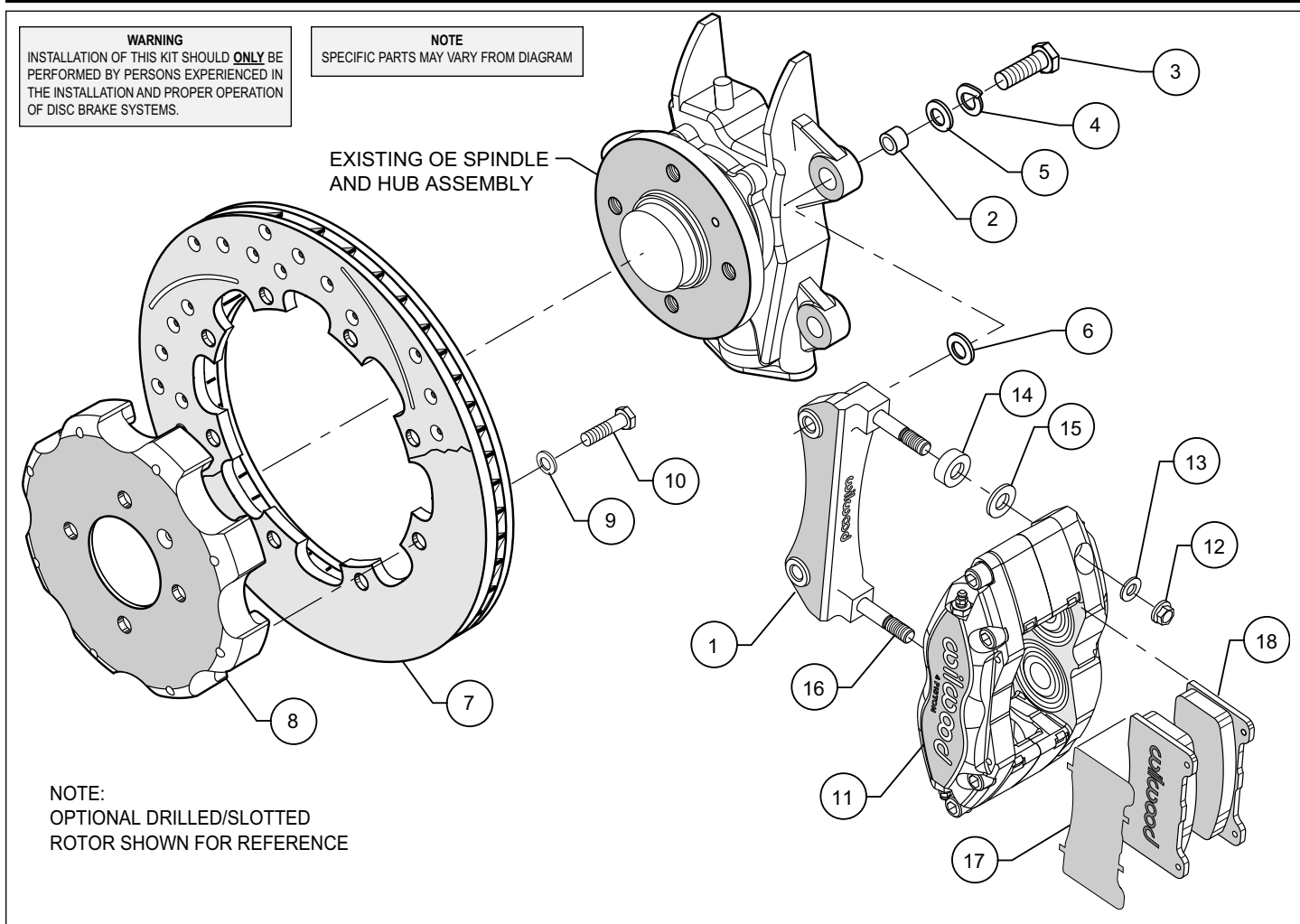

Figure 1. Typical Installation Configuration

Parts List

| ITEM NO. | PART NO. | DESCRIPTION | QTY |
|----------|----------------|---|-----|
| 1 | 250-8646 | Bracket, Caliper Mounting | 2 |
| 2 | 300-8359 | Sleeve | 4 |
| 3 | 230-8693 | Bolt, 7/16-20 x 1.50 Long | 4 |
| 4 | 240-0139 | Washer, 49/64 inch, Lock | 4 |
| 5 | 240-0476 | Washer, 59/64 inch | 4 |
| 6 | 240-5680 | Washer, 7/8 inch, Shim | 8 |
| 7 | 160-5843 | Rotor, .81" Thk x 12.19" Dia, 8 x 7.00" Bolt Circle | 2 |
| 7A | 160-7103/04-BK | Rotor, Drilled and Slotted | 2 |
| 8 | 170-10650 | Hat | 2 |
| 9 | 240-0541 | Washer, 9/16 inch | 16 |
| 10 | 230-8473 | Bolt, 5/16-18 x 1.00 Long, Hex Head | 16 |
| 11 | 120-7376 | Caliper, DynaPro | 2 |
| 12 | 230-9183 | Nut, Self-Locking Hex Head | 4 |
| 13 | 240-2510 | Washer, flat, 5/8 inch | 4 |
| 14 | 300-8764 | Spacer, .215 Long | 4 |
| 15 | 240-3736 | Washer, flat, 51/64 inch | 8 |
| 16 | 230-9078 | Stud, 3/8-16 x 3/8-24 x 2.5 Long (pre installed in bracket) | 4 |
| 17 | 300-8259 | Anti-Squeal Shim, 4 Pack | 1 |
| 18 | 150-8946K | Pad, BP-10, Axle Set | 1 |

NOTES:

Part Number 230-8390 Rotor Bolt Kit, includes part numbers 230-8473 and 240-0541

Part Number 250-8694 Caliper Bracket Mounting Bolt Kit, includes P/N's 230-9183, 230-9078, 240-3736, 240-2510, 250-8646 and 300-8764

Part Number 230-8692 Spindle Bracket Mounting Bolt Kit, includes P/N's 230-8693, 240-0139, 240-0476, 240-5680 and 300-8359

Item 7A is an optional item and is included with the "-D" kits. Add "-D" to end of part number when ordering.

Wilwood offers an optional Braided Stainless Steel Hose Kit. Order part number 220-8491 (not included in kit)

General Information, Disassembly, and Assembly Instructions

Installation of this kit should **ONLY** be performed by persons experienced in the installation and proper operation of disc brake systems. Before installation begins, please read the complete procedure thoroughly to familiarize yourself with the process, and double check the following items to ensure a trouble-free installation.

- Make sure this is the correct kit to match the exact make and model year of the vehicle's spindle.
- Verify the hat bolt pattern in this kit matches the bolt pattern of the vehicle's hubs.
- Verify your wheel clearance using Figure 2.
- Inspect the package contents against the parts list to ensure that all components and hardware are included.

Disassembly

- Disassemble the original equipment front brakes:

Raise the front wheels off the ground and support the front suspension according to the vehicle manufacturer's instructions.

Remove the wheel. Remove the two bolts that hold the stock caliper mounting bracket to the spindle. Lift off the bracket and stock caliper as one unit, then slide off the stock hat and rotor assembly. On some models you may have to unbolt the stock caliper from the caliper bracket before removal.

Remove OEM dust plate assembly by removing the four attachment bolts. Dust plate will not be reused.

- Thoroughly clean and de-grease the spindles while removing any nicks or burrs.

Assembly Instructions (numbers in parenthesis refer to the part list/diagram on the preceding pages): **CAUTION:** All mounting bolts must fully engage insert nuts. Be sure to check that all bolts are either flush or protruding through flanged side of insert nut after shimming.

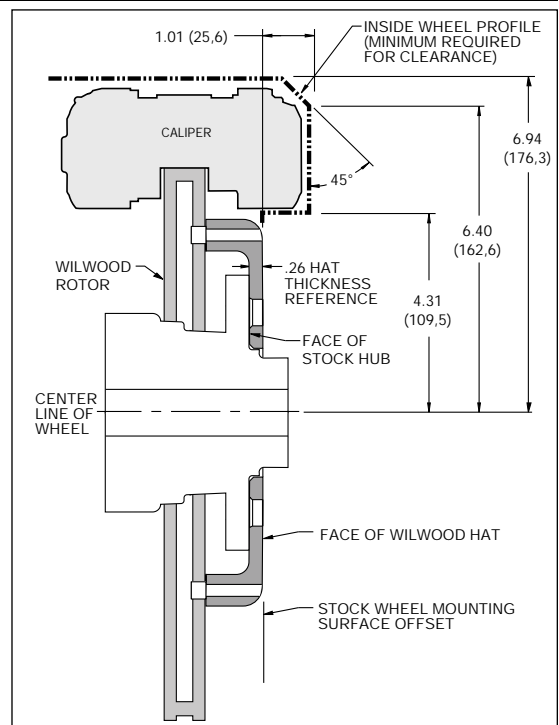

Figure 2. Wheel Clearance Diagram

Assembly Instructions (Continued)

- Insert one sleeve (2) each into the holes on the top and bottom of the spindle “ears” where the OEM caliper bracket was removed. The caliper mounting bracket assembly (1) should be installed first with clean, dry threads on the mounting bolts. Install the bracket from the rear side of the spindle by sliding bolts (3) through lockwasher (4) and flatwasher (3). Place shim washer (6) between the bracket (1) and the spindle (see Figure 1). The bracket must tighten squarely against the side of the spindle body. Inspect for interference from casting irregularities, machining ridges, burrs, etc. Use one thin shim (6) between the spacer and spindle during initial trial fitting.

- With the larger I.D. side of the rotor (6) facing away from the hat (8), bolt rotor (7) to hat (8) through the backside of the rotor using washers (10) and bolts (9). Torque bolts (8) in an alternating sequence to 120-144 **in-lb**. Safety wire bolts (9) using standard 0.032 inch diameter stainless steel safety wire as shown in Figure 3. Please refer to Wilwood’s data sheet DS-386 (available at www.wilwood.com/pdf/ds386.pdf) for complete safety wire installation instructions. Slide the rotor/hat assembly onto the spindle. Install a couple of wheel bolts (finger tighten) to keep the rotor/hat assembly in place while continuing with the installation.

- NOTE:** Please reference the caution statement at the beginning of the assembly instructions. Install spacer (14) and one washer (15) over each pre-installed stud (16) on the radial mount bracket (1). Slide the caliper (11) in place over the studs and rotors and install the washer (13) and lock nut (12) to hold the caliper in place. Snug the lock nuts (12) and check that the rotor (7) is centered in the caliper (11). Add or subtract .02" shims (6) as necessary between the caliper mounting bracket (1) and the spindle to center the caliper (11).

- Remove the caliper quick-clip pad retainer from the caliper. Remove the protective material from the adhesive side of the anti-squeal shims (17) and place against the backing plate side of the brake pads (18) utilizing the contour of the backing plate as a guide. Secure material to backing plate by bending the four tabs over the edge of the backing plate. Slide the brake pads (18) with the shims into place. They should install easily without interference. Check that the outside radius of the brake pad is aligned with the outside diameter radius of the rotor face. Add or subtract shims (15) between the caliper and mount bracket to gain the proper alignment. Reinstall the quick-clip pad retainer.

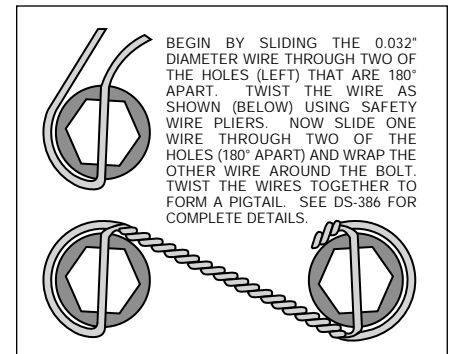

Figure 3. Safety Wire Diagram

- Remove the wheel bolts that were holding the hat in place. Install the wheel. Check to see that the wheel rotates freely without interference.

- Once all clearances have been checked, remove the wheel, caliper, hat, and rotor from the spindle and hub. Secure the caliper mounting bracket (1) to the spindle with bolt (3) using red *Loctite*[®] 271. Torque the bolts to 47 ft-lbs. Reinstall the hat and rotor assembly and again use several wheel bolts to hold it in place. Lubricate caliper mounting studs and nuts with lightweight oil, reinstall the caliper, torque the caliper nuts (12) to 30-35 ft-lb.

- NOTE:** OEM rubber brake hoses generally cannot be adapted to Wilwood calipers. The caliper inlet fitting is a 1/8-27 NPT. The preferred method is to use steel adapter fittings at the caliper, either straight, 45 or 90 degree and enough steel braided line to allow for full suspension travel and turning radius, lock to lock. **Carefully route lines to prevent contact with moving suspension, brake or wheel components.** Wilwood hose kits are designed for use in many different vehicle applications and it is the installer's responsibility to properly route and ensure adequate clearance and retention for brake hose components. Wilwood offers a hose kit, P/N 220-8491, which includes hoses, fittings, etc., all in one package for this application.

- Specified brake hose kits may not work with all Years, Makes and Models of vehicle that this brake kit is applicable to, due to possible OEM manufacturing changes during a production vehicle's life. It is the installer's responsibility to ensure that all fittings and hoses are the correct size and length, to ensure proper sealing and that they will not be subject to crimping, strain and abrasion from vibration or interference with suspension components, brake rotor or wheel.

- In absence of specific instructions for brake line routing, the installer must use his best professional judgment on correct routing and retention of lines to ensure safe operation. Test vehicle brake system per the 'minimum test' procedure stated within this document before driving. After road testing, inspect for leaks and interference. Initially after install and testing, perform frequent checks of the vehicle brake system and lines before driving, to confirm that there is no undue wear or interference not apparent from the initial test. Afterwards, perform periodic inspections for function, leaks and wear in a interval relative to the usage of vehicle.

- Bleed the brake system. Reference the general information and recommendations on page 5 for proper bleeding instructions.

- Remove the wheel bolts that were used to hold the rotor/hat assembly in place during caliper installation. Install the wheel and wheel bolts, torque to OEM specifications.

- Repeat the entire procedure for the other wheel.

Additional Information and Recommendations

•**NOTE:** With the installation of after market disc brakes, the wheel track may change depending on the application. Check your wheel offset before final assembly.

•Please read the following concerning balancing the brake bias on 4 wheel disc vehicles.

•**OE Style or Single Mount Race Pedal with Tandem Outlet Master Cylinder:**

Front to rear caliper piston sizes, rotor diameters, and pad compounds must be initially configured to provide the correct range of vehicle bias when using a single bore / tandem outlet master cylinder. If excessive rear brake bias is experienced, an inline adjustable proportioning valve can be used to decrease the rear line pressure to help bring the vehicle into balance. If excessive front brake bias is experienced, first consideration should be given to increasing the rear brake bias to bring the vehicle into overall balance.

•**Race Pedal with Dual Master Cylinders and Balance Bar:**

Master cylinders must be sized to match the calipers and allow the pedal balance bar to operate near the center of its travel. If it is not possible to fine tune the bias within the adjustable range of the balance bar, then consideration must be given to changing a master cylinder bore size or some other aspect of the brake system to bring the car into balance. Larger bore master cylinders will generate less pressure while decreasing pedal travel. Smaller bores master cylinders will generate higher line pressures with an increase in pedal travel.

•For optimum performance, fill and bleed the new system with Wilwood Hi-Temp[®] 570 grade fluid or EXP 600 Plus. For severe braking or sustained high heat operation, use Wilwood EXP 600 Plus Racing Brake Fluid. Used fluid must be completely flushed from the system to prevent contamination. **NOTE:** Silicone DOT 5 brake fluid is **NOT** recommended.

•To properly bleed the brake system, begin with the caliper farthest from the master cylinder. Bleed the outboard bleed screw first, then the inboard. Repeat the procedure until all calipers in the system are bled, ending with the caliper closest to the master cylinder. If the caliper is fitted with bleed screws on four corners, make sure the bottom bleed screws are tight. Only bleed from the top bleed screws. **NOTE:** When using a new master cylinder, it is important to bench bleed the master cylinder first.

•Test the brake pedal. It should be firm, not spongy, and stop at least 1 inch from the floor under heavy load.
If the brake pedal is spongy, bleed the system again.

If the brake pedal is initially firm, but then sinks to the floor, check the system for leaks. Correct the leaks (if applicable) and then bleed the system again.

If the brake pedal goes to the floor and continued bleeding of the system does not correct the problem, either air may be trapped in the system, or a master cylinder with increased capacity (larger bore diameter) may be required. Wilwood offers various lightweight master cylinders with large fluid displacement capacities (custom fabricated mounting may be required).

Brake Testing and Pad Bedding

WARNING • DO NOT DRIVE ON UNTESTED BRAKES BRAKES MUST BE TESTED AFTER INSTALLATION OR MAINTENANCE MINIMUM TEST PROCEDURE

- Make sure pedal is firm: Hold firm pressure on pedal for several minutes, it should remain in position without sinking. If pedal sinks toward floor, check system for fluid leaks. DO NOT drive vehicle if pedal does not stay firm or can be pushed to the floor with normal pressure.
- At very low speed (2-5 mph) apply brakes hard several times while turning steering from full left to full right, repeat several times. Remove the wheels and check that components are not touching, rubbing, or leaking.
- Carefully examine all brake components, brake lines, and fittings for leaks and interference.
- Make sure there is no interference with wheels or suspension components.
- Drive vehicle at low speed (15-20 mph) making moderate and hard stops. Brakes should feel normal and positive. Again check for leaks and interference.
- Always test vehicle in a safe place where there is no danger to (or from) other people or vehicles.
- Always wear seat belts and make use of all safety equipment.

PAD BEDDING PROCEDURE:

• Pump brakes at low speed to assure proper operation. On the race track, or other safe location, make a series of hard stops until some brake fade is experienced. Allow brakes to cool while driving at moderate speed to avoid use of the brakes. This process will properly burnish the brake pads, offering maximum performance.

Associated Components

| <u>PART NO.</u> | <u>DESCRIPTION</u> |
|------------------------|--|
| 260-1874 | Wilwood Residual Pressure Valve (2 lb for disc brakes) |
| 260-1876 | Wilwood Residual Pressure Valve (10 lb for drum brakes) |
| 260-8419 | Wilwood Proportioning Valve |
| 290-0632 | Wilwood Racing Brake Fluid (Hi-Temp° 570) (12 oz) |
| 290-6209 | Wilwood Racing Brake Fluid (EXP 600 Plus) (16.9 oz) |
| 340-1285 | Wilwood Floor Mount Brake Pedal (with balance bar) |
| 340-1287 | Wilwood Swing Mount Brake Pedal (with balance bar) |
| 260-6764 | Wilwood 3/4 inch High Volume Aluminum Master Cylinder |
| 260-6765 | Wilwood 7/8 inch High Volume Aluminum Master Cylinder |
| 260-6766 | Wilwood 1 inch High Volume Aluminum Master Cylinder |
| 260-8555 | Wilwood 1 inch Aluminum Tandem Chamber Master Cylinder |
| 260-8556 | Wilwood 1-1/8 inch Aluminum Tandem Chamber Master Cylinder |
| 270-2016 | Quick Release Steering Hub (3/4 inch shaft) |
| 270-2017 | Quick Release Steering Hub (5/8 inch shaft) |
| 220-8491 | Flexline Kit, Mini-Cooper |