



D8-4 REPLACEMENT CALIPERS 1965-82 CHEVROLET CORVETTE*

Caliper Highlights:

The D8-4 is a direct bolt-on replacement for the factory original calipers on all 1965-82 Corvette's. Forged billet aluminum bodies, stainless steel pistons, and competition style high-temperature seals put an end to the rust, bore pitting, and seal failures that plague the OE caliper design. D8-4 calipers provide low-maintenance performance for the Sunday afternoon driver, and a huge weight savings with high temperature reliability for the tracks.

Direct OE Mounting:

D8-4 calipers mount in the stock location over stock rotors, and use the original style OE D8 brake pads. D8-4 calipers are designed to fit the factory steel wheel and most optional factory aluminum wheels*. The factory piston sizes were duplicated to maintain the original front to rear brake bias and use of the OE master cylinder. Only the flex lines that connect the caliper with the hard line fittings on the chassis need to be replaced to install the D8-4 on any car.

Forged Billet Aluminum Bodies:

D8-4 calipers are the product of Wilwood's in-house FEA design and 3-D modeling technology. With its unyielding strength and superior piston design, the D8-4 generates positive pedal response and high clamping efficiency with a substantial weight savings over the OE calipers. As compared to the individual weight of 13.2 pounds each for the OE calipers, a full set of D8-4 calipers reduces unsprung suspension weight by 29 pounds. Base model calipers feature a natural aluminum finish protected by a durable clear coat anodizing. Gloss red, black, and polished calipers are also available for custom and show applications.



Above: D8 Front Caliper Shown in Natural Aluminum Finish



Above: D8 Rear Caliper Shown in Black Powder Coat Finish

Performance and Reliability for the Street or Track:

Forged billet aluminum calipers with stainless steel pistons and high temperature seals eliminate the rust, bore corrosion, and seal failures that are common to the OE caliper design. At the track, the stainless pistons delay the heat transfer from the pads while the aluminum calipers dissipate the heat quicker than the OE cast iron calipers. Cooler operating temperatures translate into longer service life, regardless of the driving environment. Each caliper also uses stainless SRS bridge plates to reduce wear from pad gouging at the caliper bridge. The spring-loaded action of the SRS plates also reduces noise by eliminating pad rattle and dampening the engagement harmonics that can contribute to pad squeal. The D8-4 can be conveniently run on standard OE replacements pads, or fine-tuned to driving conditions with one of the five Wilwood performance compound formulas.

ORDERING INFORMATION, CALIPERS:

CALIPER	BORE SIZE		DISC WIDTH		CALIPER P/N	FLEXLINE KIT P/N
Front	1.88"	47,8 mm	1.25"	31,8 mm	120-10525 ^(1,2,3)	220-10631
Rear	1.38"	35,1 mm	1.25"	31,8 mm	120-10526 ^(1,2,3)	220-10632

NOTES: (1) AVAILABLE RED, ADD "RD" TO END OF PART NUMBER WHEN ORDERING
 (2) AVAILABLE BLACK, ADD "BK" TO END OF PART NUMBER WHEN ORDERING
 (3) AVAILABLE POLISHED, ADD "P" TO END OF PART NUMBER WHEN ORDERING

*Fits C2 and C3 Factory Steel Wheels and C3 Factory Optional Aluminum Wheels.
 Does not fit Kelsey Hayes or Replica Knock-Off Wheels.

4700 Calle Bolero • Camarillo, CA 93012 • www.wilwood.com • Sales: 805 / 388-1188 • Fax: 805 / 388-4938

D8-4 FRONT CALIPER, MOUNTING DIMENSIONS:

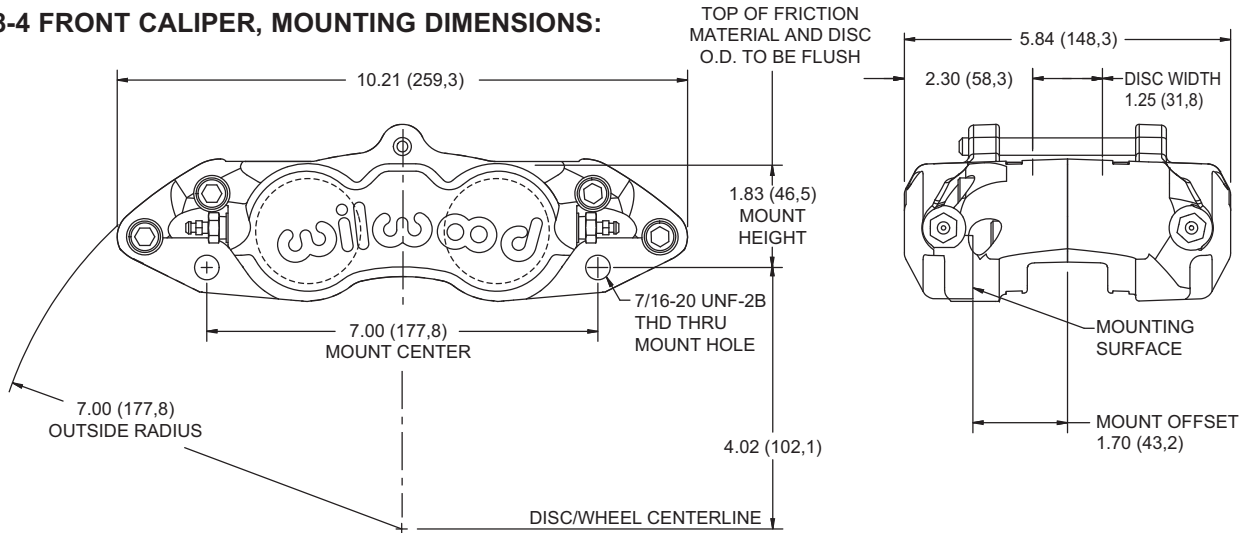

NOTE: DIMENSIONS FOR USE WITH 1965-82 STOCK FRONT CORVETTE ROTOR, 11.75 (298,5) X 1.25 (31,8)
INLET FITTING: 1/8-27 NPT

D8-4 REAR CALIPER, MOUNTING DIMENSIONS:

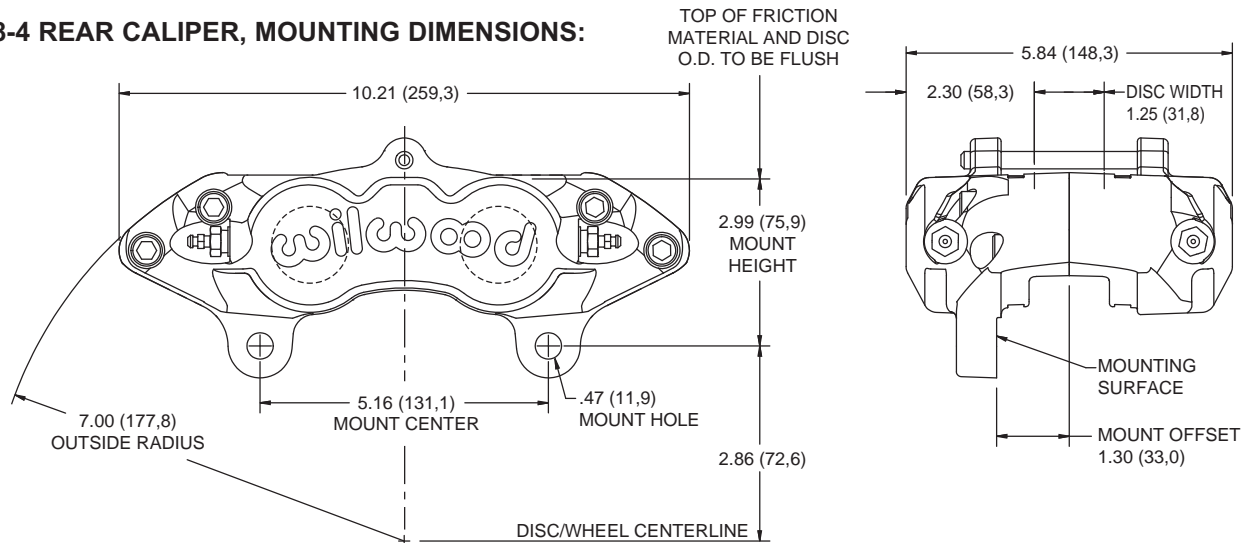

NOTE: DIMENSIONS FOR USE WITH 1965-82 STOCK REAR CORVETTE ROTOR, 11.75 (298,5) X 1.25 (31,8)
INLET FITTING: 1/8-27 NPT

D8-4 CALIPER, TYPE D8 PAD DIMENSIONS AND ORDERING INFORMATION:

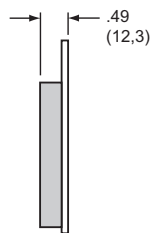
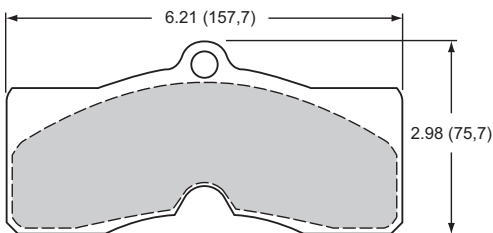

AXLE SET P/N

150 - 10546K
150 - 10547K
15A - 6202K
15E - 8300K
15Q - 8623K

PAD TYPE / COMPOUND

D8 10 BP-10 Smart Pad
D8 20 BP-20 Smart Pad
D8 A PolyMatrix
D8 E PolyMatrix
D8 Q PolyMatrix

ORDERING INFORMATION, USER SERVICEABLE COMPONENTS:

CALIPER PART NO.	PISTON	SQ RING (EA)	BLEED SCREW KIT (4 PK)	BODY SEAL (EA)	BRIDGE WEAR PLATE (EA)	PAD RETAINER CLIP PIN (EA)
120-10525	200-7521 (1.88")	210-5445	220-0627	210-2582	300-10523	310-3634
120-10526	200-7516 (1.38")	210-5442	220-0627	210-2582	300-10523	310-3634