

ASSEMBLY INSTRUCTIONS
FOR
DYNALITE PRO SERIES FRONT HUB KIT
WITH 10.75" DIAMETER VENTED ROTOR

1965 - 1972 MOPAR "A" BODY, 10" DRUM

PART NUMBER GROUP

140-2723-B

**DISC BRAKES SHOULD ONLY BE INSTALLED BY SOMEONE
EXPERIENCED AND COMPETENT IN THE INSTALLATION
AND MAINTENANCE OF DISC BRAKES**

READ ALL WARNINGS

WARNING

IT IS THE RESPONSIBILITY OF THE PERSON INSTALLING ANY BRAKE COMPONENT OR KIT TO DETERMINE THE SUITABILITY OF THE COMPONENT OR KIT FOR THAT PARTICULAR APPLICATION. IF YOU ARE NOT SURE HOW TO SAFELY USE THIS BRAKE COMPONENT OR KIT, YOU SHOULD NOT INSTALL OR USE IT. DO NOT ASSUME ANYTHING. IMPROPERLY INSTALLED OR MAINTAINED BRAKES ARE DANGEROUS. IF YOU ARE NOT SURE, GET HELP OR RETURN THE PRODUCT. YOU MAY OBTAIN ADDITIONAL INFORMATION AND TECHNICAL SUPPORT BY CALLING WILWOOD AT (805) 388-1188, OR VISIT OUR WEB SITE AT WWW.WILWOOD.COM. USE OF WILWOOD TECHNICAL SUPPORT DOES NOT GUARANTEE PROPER INSTALLATION. **YOU**, OR THE PERSON WHO DOES THE INSTALLATION MUST KNOW HOW TO PROPERLY USE THIS PRODUCT. IT IS NOT POSSIBLE OVER THE PHONE TO UNDERSTAND OR FORESEE ALL THE ISSUES THAT MIGHT ARISE IN YOUR INSTALLATION.

RACING EQUIPMENT AND BRAKES MUST BE MAINTAINED AND SHOULD BE CHECKED REGULARLY FOR FATIGUE, DAMAGE, AND WEAR.



WARNING

DO NOT OPERATE ANY VEHICLE ON UNTESTED BRAKES!
SEE MINIMUM TEST PROCEDURE WITHIN

ALWAYS UTILIZE SAFETY RESTRAINT SYSTEMS AND ALL OTHER AVAILABLE SAFETY EQUIPMENT WHILE OPERATING THE VEHICLE

IMPORTANT • READ THE DISCLAIMER OF WARRANTY INCLUDED IN THE KIT

NOTE: Some cleaners may stain or remove the finish on brake system components. Test the cleaner on a hidden portion of the component before general use.

Important Notice - Read This First

Before any tear-down or disassembly begins, review the following information:

- Review the wheel clearance diagram (figure 2, page 3) to verify that there is adequate clearance with the wheels you will be using with the installation.
- Front brake kits do not include flex lines. OEM brake lines will not adapt to Wilwood calipers. Check the assembly instructions, or associated components section for brake line recommendations before assembly. In addition, Wilwood offers an extensive listing of brake lines and fitting on our web site: www.wilwood.com.
- Due to OEM production differences and other variations from vehicle to vehicle, the fastener hardware and other components in this kit may not be suitable for a specific application or vehicle.
- It is the responsibility of the purchaser and installer of this kit to verify suitability / fitment of all components and ensure all fasteners and hardware achieve complete and proper engagement. Improper or inadequate engagement can lead to component failure.

Exploded Assembly Diagram

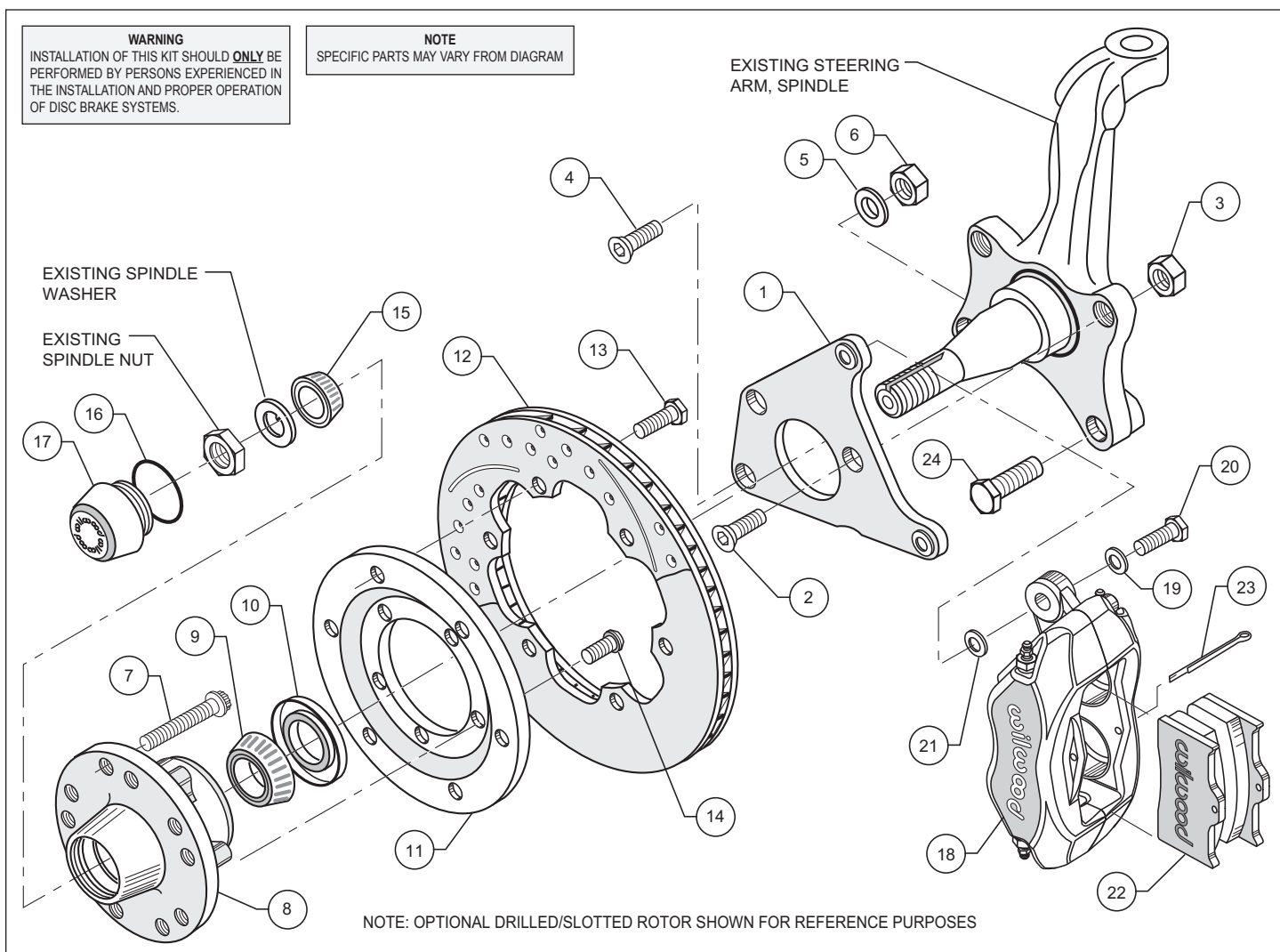

Figure 1. Typical Configuration, Drum Spindle

Parts List

ITEM NO.	PART NO.	DESCRIPTION	QTY
1	249-3113/14	Brackets, Caliper (pair, one each, left and right)	1
2	230-3145	Bolt, 7/16-20 x 1.50 Long, FHCS	4
3	230-1456	Nut, Lock 7/16-20	4
4	230-3144	Bolt, 1/2-20 x 2.75 Long, FHCS	2
5	240-11102	Washer, 1/2 inch	2
6	230-0819	Nut, Hex 1/2-20	2
7	230-2187	Stud, 1/2-20 x 1.75 Long, 12 Point	10
8	270-8767	Hub Assembly	2
9	370-0879	Cone, Inner Bearing	2
10	380-3232	Seal, Grease	2
11	300-3307	Adapter, Rotor	2
12	160-5839	Rotor, .81" Thk x 10.75" Dia, 6 x 6.25" Bolt Circle	2
12A	160-7097/98	Rotor, Drilled and Slotted (pair, one each, left and right)	2
13	230-2043	Bolt, 5/16-18 x 0.75 Long	12
14	230-11239	Bolt, 3/8-16 x 1.00 Long, Torx Button Head	10
15	370-0877	Cone, Outer Bearing	2
16	211-1674	O-ring	2
17	270-2158	Cap, Dust	2
18	120-6816	Caliper, Forged Dynalite	2
18A	120-6796-P	Caliper, Forged Dynalite, Polished	2
19	240-10190	Washer, .391 I.D. x .625 O.D. x .063 Thick	4
20	230-0228	Bolt, 3/8-24 x 1.25 Long, Hex Head	4
21	240-1159	Washer, Shim, .032 thick	16
22	150-8850K	Pad, BP-10, Axle Set	1
23	180-0055S	Pin, Cotter	2
24	230-3143	Bolt, 1/2-20 x 2.25 Long, Hex Head	2

NOTES: Part Number 230-3829 Bolt Kit, adapter plate to hub, includes part number 230-11239
 Part Number 230-3328 Bolt Kit, rotor to adapter plate, includes part number 230-2043
 Part Number 230-0204 Bolt Kit, caliper to bracket, includes part numbers 230-0228, 240-10190 and 240-1159
 Part Number 230-3153 Bolt Kit, bracket to spindle, includes p/n's 230-3145, 230-1456, 230-3143, 230-0819, 230-3144 & 240-11102
 Item 12A is an optional item and is included in the (D) drilled kits
 Item 18A is an optional item and is included in the (P) polished kits

General Information

Installation of this kit should **ONLY** be performed by persons experienced in the installation and proper operation of disc brake systems. Before assembling the Wilwood front disc brake kit, double check the following items to ensure a trouble-free installation.

- Make sure this is the correct kit to match the exact make and model year of the vehicles spindle (i.e., hubs for a 1975 Chrysler-Dodge-Plymouth (CDP) spindle will not fit a 1962 CDP spindle).
- Verify the hub stud pattern in this kit matches the stud pattern of the vehicles wheels.
- Verify your wheel clearance using Figure 2.
- CDP hubs have a 5 x 4.50" and 5 x 4.00" pattern. The 5 x 4.00" pattern does not guarantee fitment with all 5 x 4.00" wheels, either OEM or aftermarket. It is important that wheel center hole clearance be 3.130" or larger to clear hub snout in the kit.
- Inspect the package contents against the parts list to ensure that all components and hardware are included.

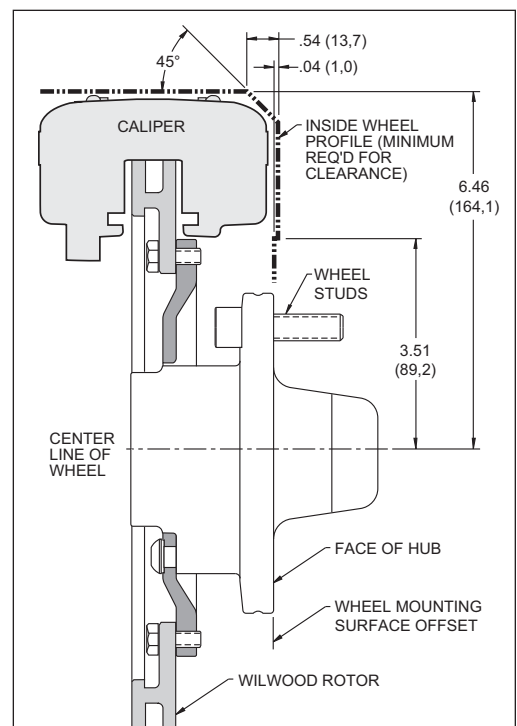

Figure 2. Wheel Clearance Diagram

Disassembly and Assembly Instructions

Disassembly Instructions

- Disassemble the original equipment front brakes:

Raise the front wheels off the ground and support the front suspension according to the vehicle manufacturer's instructions.

Remove the center cap, cotter pin, nut lock and the wheel bearing nut and washer. Save the wheel bearing nut and nut lock. Remove the brake drum and hub assembly, including the wheel bearings. Disconnect the brake hoses from the brake line at the body. Remove the two upper backing plate retaining nuts and bolts. Remove the two lower ball joint to spindle nuts and bolts. The backing plate, spindle and ball joint will now separate. Remove the brake backing plate and shoes as an assembly. Reinstall the rear ball joint bolt and nut. Do not tighten at this time. Do not reinstall the rear bolt and nut.

- Clean and de-grease the spindles.

Assembly Instructions (number in parenthesis refer to the parts list/diagram on the preceding page): **CAUTION:** All mounting bolts must fully engage insert nuts. Be sure to check that all bolts are either flush or protruding through flanged side of each insert nut after shimming.

- Identify the left and right caliper mounting brackets (1). Both brackets will be offset to the rear of the vehicle with the threaded inserts and the beveled bolt holes facing the outside of the vehicle. Apply red *Loctite*® 271 to bolt threads (2 and 4) before assembly of the caliper bracket (1) to dust face plate of spindle. Insert the two upper mounting bolts (2) and the lower mounting bolt (4) through the caliper mounting bracket (1). Install two lock nuts (3) on the upper mounting bolts (2) and finger tighten. Install one washer (5) and one lock nut (6) on the lower mounting bolt (4) and finger tighten. Torque two bolts (2) to 47 ft-lb. Torque bolt (4) and (24) to 77 ft-lb. **NOTE:** Be sure the heads of the caliper bracket (1) insert nuts are facing outward toward the wheel.

- Install five new wheel studs (7) into the hub (8). Torque to 77 ft-lb. **NOTE:** There are two five lug patterns in the hub (5 x 4.00 and 5 x 4.50). Make sure of the correct hole pattern for the correct wheel application before installing studs into hub.

- Pack the large inner bearing cone (9) with high temperature disc brake bearing grease (available from your local auto parts store) and install into the backside of the hub (8). Install the grease seal (10) by pressing into the backside of the hub (8).

- Attach rotor adapter (11) to rotor (12) using six bolts (13). Torque bolts (13) to 180 in-lb. Safety wire bolts (13) using standard 0.032 inch diameter stainless steel safety wire as shown in Figure 3. Please refer to Wilwood's data sheet DS-386 (available at www.wilwood.com/Pdf/DataSheets/ds386.pdf) for complete safety wire installation instructions. **NOTE:** The flat side of the rotor (12) lugs face toward the rotor adapter (11) with the dished side of the rotor adapter (11) facing away from the rotor (12).

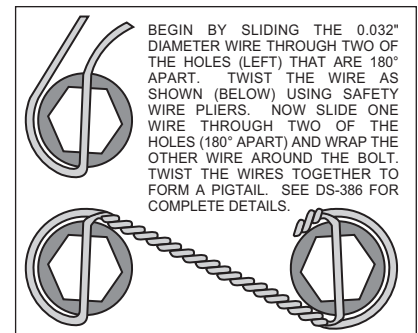

Figure 3. Safety Wire Diagram

- Mount the adapter/rotor assembly (11/12) to the hub (8) using bolts (14) (finger tight), as shown in Figure 1. Using an alternating sequence, remove bolts one at a time, apply red *Loctite*® 271 to the threads, and torque to 55 ft-lb.

- Pack the small outer bearing cone (15) with high temperature disc brake bearing grease. Lightly coat the spindle bearing surfaces with bearing grease. Slide the hub/rotor assembly (8 and 12) with outer bearing cone (15) onto the spindle. Secure using existing spindle washer, existing adjusting nut and nut locking device (adjust bearings per original equipment manufacturer specifications).

- Install the dust cap (17) onto the hub (8). Friction created by the o-ring (16) on the dust cap (17) keeps it from unscrewing. The O.D. of the existing spindle washer may be larger than the I.D. of the dust cap (17) not allowing it to seat against the hub face. Some grinding of the washer O.D. may be necessary to clear the I.D. of the dust cap.

- NOTE:** Please reference the caution statement at the beginning of the assembly instructions. Mount the caliper (18) onto the caliper mounting bracket (1) using two bolts (20) and two washers (19). View the rotor (12) through the top of the caliper (18). The rotor (12) should be aligned in the center of the caliper (18). If not, loosen the two bolts (20) and adjust the caliper (18) by using 0.032 inch thick shim washers (21). The shim washers (21) should be placed between the caliper (18) and the caliper mounting bracket (1). Finger tighten and recheck alignment. Add as many shim washers (21) as necessary to achieve the correct alignment. **NOTE:** The end of the bolt must be flush with or slightly protruding from the head of the clinch nut. See Figure 4. Place spare shims (21) between washer and caliper mounting ear to achieve the proper mounting fastener configuration. Always use the same amount of shims on both the top and bottom caliper mounting bolts (20). Loosen the two bolts (20) and apply red *Loctite*® 271 to bolt threads (20) and torque to 40 ft-lb. Safety wire the two bolts (20).

Assembly Instructions (Continued)

•Install the disc brake pads (22) and secure using cotter pin (23). Repeat this procedure for the other wheel.

•**NOTE:** OEM rubber brake hoses generally cannot be adapted to Wilwood calipers. The caliper inlet fitting is a 1/8-27 NPT. The preferred method is to use steel adapter fittings at the caliper, either straight, 45 or 90 degree and enough steel braided line to allow for full suspension travel and turning radius, lock to lock. **Carefully route lines to prevent contact with moving suspension, brake or wheel components.** Wilwood hose kits are designed for use in many different vehicle applications and it is the installer's responsibility to properly route and ensure adequate clearance and retention for brake hose components.

•Specified brake hose kits may not work with all Years, Makes and Models of vehicle that this brake kit is applicable to, due to possible OEM manufacturing changes during a production vehicle's life. It is the installer's responsibility to ensure that all fittings and hoses are the correct size and length, to ensure proper sealing and that they will not be subject to crimping, strain and abrasion from vibration or interference with suspension components, brake rotor or wheel.

•In absence of specific instructions for brake line routing, the installer must use his best professional judgment on correct routing and retention of lines to ensure safe operation. Test vehicle brake system per the 'minimum test' procedure stated within this document before driving. After road testing, inspect for leaks and interference. Initially after install and testing, perform frequent checks of the vehicle brake system and lines before driving, to confirm that there is no undue wear or interference not apparent from the initial test. Afterwards, perform periodic inspections for function, leaks and wear in a interval relative to the usage of vehicle.

•Bleed the brake system. Reference the general information and recommendations on page 6 for proper bleeding instructions.

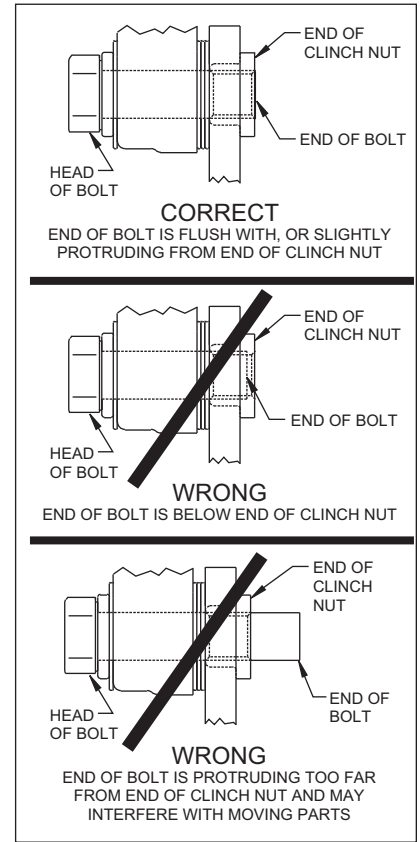

Figure 4.
Clinch Nut Engagement Diagram

Additional Information and Recommendations

•Please read the following concerning balancing the brake bias on 4 wheel disc vehicles.

•**OE Style or Single Mount Race Pedal with Tandem Outlet Master Cylinder:**

Front to rear caliper piston sizes, rotor diameters, and pad compounds must be initially configured to provide the correct range of vehicle bias when using a single bore / tandem outlet master cylinder. If excessive rear brake bias is experienced, an inline adjustable proportioning valve can be used to decrease the rear line pressure to help bring the vehicle into balance. If excessive front brake bias is experienced, first consideration should be given to increasing the rear brake bias to bring the vehicle into overall balance.

•**Race Pedal with Dual Master Cylinders and Balance Bar:**

Master cylinders must be sized to match the calipers and allow the pedal balance bar to operate near the center of its travel. If it is not possible to fine tune the bias within the adjustable range of the balance bar, then consideration must be given to changing a master cylinder bore size or some other aspect of the brake system to bring the car into balance. Larger bore master cylinders will generate less pressure while decreasing pedal travel. Smaller bores master cylinders will generate higher line pressures with an increase in pedal travel.

•Fill and bleed the new system with Wilwood Hi-Temp° 570 grade fluid or higher. For severe braking or sustained high heat operation, use Wilwood EXP 600 Plus Racing Brake Fluid. Used fluid must be completely flushed from the system to prevent contamination.

NOTE: *Silicone DOT 5 brake fluid is **NOT** recommended for racing or performance driving.*

•To properly bleed the brake system, begin with the caliper farthest from the master cylinder. Bleed the outboard bleed screw first, then the inboard. Repeat the procedure until all calipers in the system are bled, ending with the caliper closest to the master cylinder.

NOTE: *When using a new master cylinder, it is important to bench bleed the master cylinder first.*

•If the master cylinder is mounted lower than the disc brake calipers, some fluid flowback to the master cylinder reservoir may occur, creating a vacuum effect that retracts the caliper pistons into the housing. This will cause the pedal to go to the floor on the first stroke until it has “pumped up” and moved all the pistons out against the pad again. A Wilwood in-line two pound residual pressure valve, installed near the master cylinder will stop the fluid flowback and keep the pedal firm and responsive.

•Test the brake pedal. It should be firm, not spongy and stop at least 1 inch from the floor under heavy load.

If the brake pedal is spongy, bleed the system again.

If the brake pedal is initially firm, but then sinks to the floor, check the system for fluid leaks. Correct the leaks (if applicable) and then bleed the system again.

If the brake pedal goes to the floor and continued bleeding of the system does not correct the problem, a master cylinder with increased capacity (larger bore diameter) will be required. Wilwood offers various lightweight master cylinders with large fluid displacement capacities.

•**NOTE:** *With the installation of after market disc brakes, the wheel track may change depending on the application. Check your wheel offset before final assembly.*

•On some models of disc brake spindles there are “ears” where the OEM calipers were mounted and these “ears” interfere with the assembly of the Wilwood disc brake kit. If it becomes necessary to remove these “ears”, remove as little as possible being careful not to cut away any of the mounting holes that may be required to bolt on the caliper mounting bracket.

•If after following the instructions, you still have difficulty in assembling or bleeding your Wilwood disc brakes, consult your local chassis builder, or retailer where the kit was purchased for further assistance.

Brake Testing and Pad Bedding

WARNING • DO NOT DRIVE ON UNTESTED BRAKES BRAKES MUST BE TESTED AFTER INSTALLATION OR MAINTENANCE MINIMUM TEST PROCEDURE

- Make sure pedal is firm: Hold firm pressure on pedal for several minutes, it should remain in position without sinking. If pedal sinks toward floor, check system for fluid leaks. DO NOT drive vehicle if pedal does not stay firm or can be pushed to the floor with normal pressure.
- At very low speed (2-5 mph) apply brakes hard several times while turning steering from full left to full right, repeat several times. Remove the wheels and check that components are not touching, rubbing, or leaking.
- Carefully examine all brake components, brake lines, and fittings for leaks and interference.
- Make sure there is no interference with wheels or suspension components.
- Drive vehicle at low speed (15-20 mph) making moderate and hard stops. Brakes should feel normal and positive. Again check for leaks and interference.
- Always test vehicle in a safe place where there is no danger to (or from) other people or vehicles.
- Always wear seat belts and make use of all safety equipment.

PAD BEDDING PROCEDURE:

• Pump brakes at low speed to assure proper operation. On the race track, or other safe location, make a series of hard stops until some brake fade is experienced. Allow brakes to cool while driving at moderate speed to avoid use of the brakes. This process will properly burnish the brake pads, offering maximum performance.

Associated Components

<u>PART NO.</u>	<u>DESCRIPTION</u>
260-1874	Wilwood Residual Pressure Valve (2 lb for disc brakes)
260-1876	Wilwood Residual Pressure Valve (10 lb for drum brakes)
260-8419	Wilwood Proportioning Valve
290-0632	Wilwood Racing Brake Fluid (Hi-Temp° 570) (12 oz)
290-6209	Wilwood Racing Brake Fluid (EXP 600 Plus) (16.9 oz)
340-1285	Wilwood Floor Mount Brake Pedal (with balance bar)
340-1287	Wilwood Swing Mount Brake Pedal (with balance bar)
260-6764	Wilwood 3/4 inch High Volume Aluminum Master Cylinder
260-6765	Wilwood 7/8 inch High Volume Aluminum Master Cylinder
260-6766	Wilwood 1 inch High Volume Aluminum Master Cylinder
260-4893	1-1/16 inch Tandem Master Cylinder (aluminum housing)
250-2406	Mounting Bracket Kit (tandem master cylinder)
260-8555	Wilwood 1 inch Aluminum Tandem Chamber Master Cylinder
260-8556	Wilwood 1-1/8 inch Aluminum Tandem Chamber Master Cylinder
350-2038	1971 - 1973 Pinto Rack and Pinion (new, not rebuilt)
270-2016	Quick Release Steering Hub (3/4 inch shaft)
270-2017	Quick Release Steering Hub (5/8 inch shaft)
220-7056	Flexline Kit, Universal, 14 Inch, Domestic
220-7699	Flexline Kit, Universal, 16 Inch, Domestic
220-8307	Flexline Kit, Universal, 18 Inch, Domestic