

ASSEMBLY INSTRUCTIONS

FOR

1988-2004 HONDA CIVIC REAR DRUM*

*For additional vehicle compatibility, visit www.wilwood.com

HM7 REAR PARKING BRAKE KIT WITH 9.39" SOLID ROTORS AND FLEXLINES

BASE PART NUMBER

140-18343

**DISC BRAKES SHOULD ONLY BE INSTALLED BY SOMEONE
EXPERIENCED AND COMPETENT IN THE INSTALLATION AND
MAINTENANCE OF DISC BRAKES
READ ALL WARNINGS**

WARNING

IT IS THE RESPONSIBILITY OF THE PERSON INSTALLING ANY BRAKE COMPONENT OR KIT TO DETERMINE THE SUITABILITY OF THE COMPONENT OR KIT FOR THAT PARTICULAR APPLICATION. IF YOU ARE NOT SURE HOW TO SAFELY USE THIS BRAKE COMPONENT OR KIT, YOU SHOULD NOT INSTALL OR USE IT. DO NOT ASSUME ANYTHING. IMPROPERLY INSTALLED OR MAINTAINED BRAKES ARE DANGEROUS. IF YOU ARE NOT SURE, GET HELP OR RETURN THE PRODUCT. YOU MAY OBTAIN ADDITIONAL INFORMATION AND TECHNICAL SUPPORT BY CALLING WILWOOD AT (805) 388-1188, OR VISIT OUR WEB SITE AT WWW.WILWOOD.COM. USE OF WILWOOD TECHNICAL SUPPORT DOES NOT GUARANTEE PROPER INSTALLATION. **YOU**, OR THE PERSON WHO DOES THE INSTALLATION MUST KNOW HOW TO PROPERLY USE THIS PRODUCT. IT IS NOT POSSIBLE OVER THE PHONE TO UNDERSTAND OR FORESEE ALL THE ISSUES THAT MIGHT ARISE IN YOUR INSTALLATION.

RACING EQUIPMENT AND BRAKES MUST BE MAINTAINED AND SHOULD BE CHECKED REGULARLY FOR FATIGUE, DAMAGE, AND WEAR.



Need Additional Information? Use Your
SmartPhone and Jump to Our Technical
Tips Section on Our Web Site.

DISC BRAKES
wilwood

WARNING

**DO NOT OPERATE ANY VEHICLE ON UNTESTED BRAKES!
SEE MINIMUM TEST PROCEDURE WITHIN**

ALWAYS UTILIZE SAFETY RESTRAINT SYSTEMS AND ALL OTHER AVAILABLE SAFETY EQUIPMENT WHILE OPERATING THE VEHICLE

IMPORTANT • READ THE DISCLAIMER OF WARRANTY INCLUDED IN THE KIT

NOTE: Some cleaners may stain or remove the finish on brake system components. Test the cleaner on a hidden portion of the component before general use.

WHEEL CLEARANCE DIAGRAM

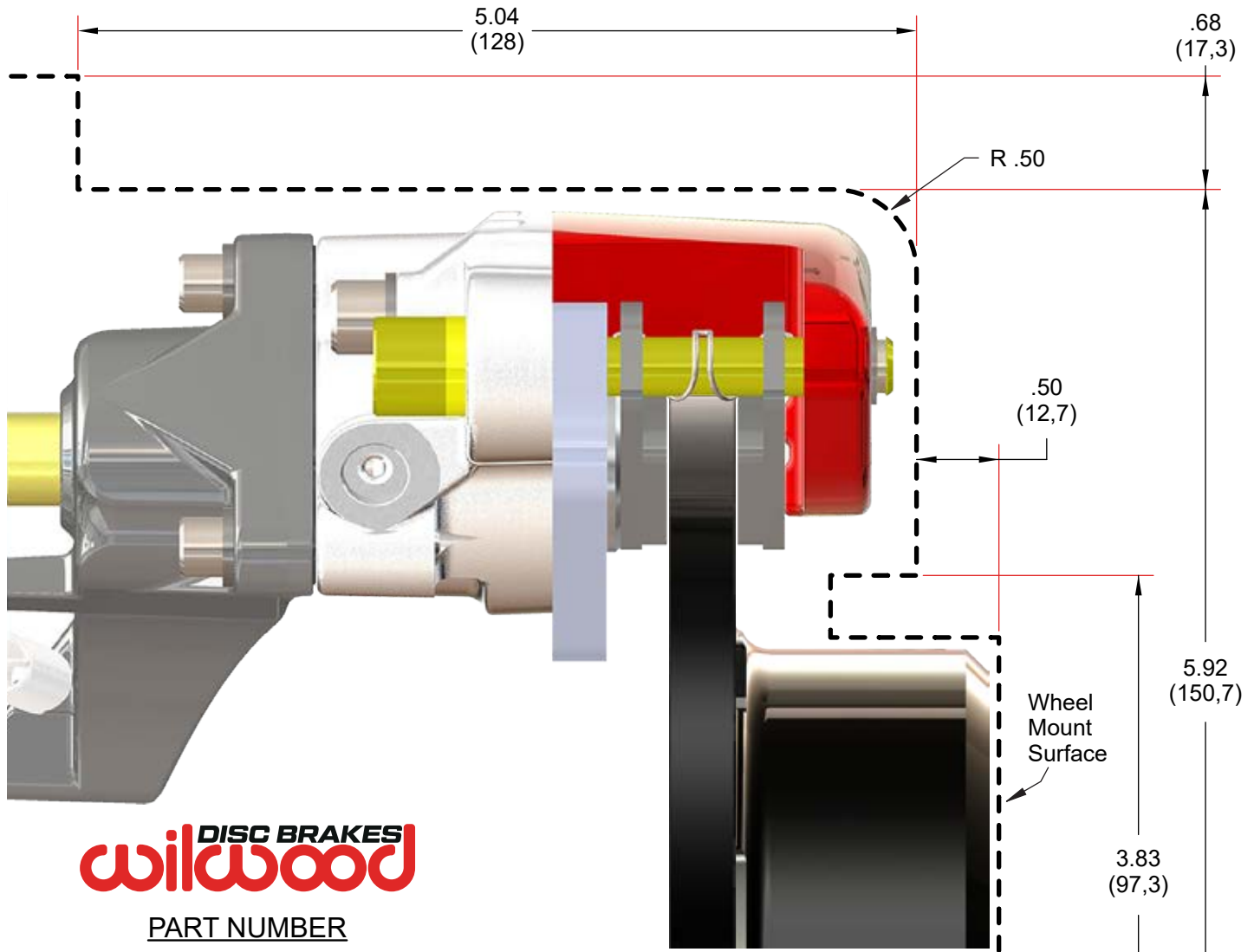

PART NUMBER

140-18340

INSTRUCTIONS

1. Print this template and verify a 1:1 scale using a ruler against both axes provided before proceeding. Adjust print scale percentage if necessary.
2. Adhere template smoothly to a piece of cardboard or sturdy construction paper.
3. Measure wheel center hole diameter. Find corresponding measurement shown in **Wheel Center Hole Diameter Chart**. Cut template following the bold, dashed lines and along the matching center hole diameter lines.
4. Fit template into wheel and determine if adequate clearance is present. A minimum of .080" clearance must be maintained between the wheel and caliper in all areas.
5. Minimum wheel center hole diameter is **2.21"**.

NOTE: Actual parts may vary. Use this template as a guideline to determine your wheel clearance before attempting installation.

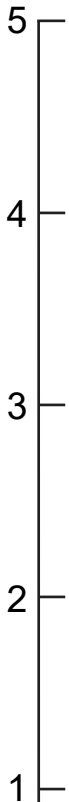

SCALE



Wheel Hub Center Line

2.58 (65,5)
2.46 (62,5)
2.33 (59,2)

2.21 (56,1) Wheel Center Hole Diameter Chart

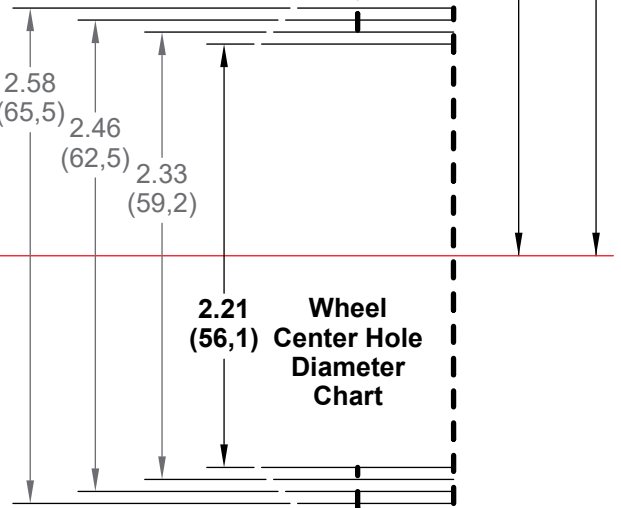

Exploded Assembly Diagram

WARNING
 INSTALLATION OF THIS KIT SHOULD **ONLY** BE PERFORMED BY PERSONS EXPERIENCED IN THE INSTALLATION AND PROPER OPERATION OF DISC BRAKE SYSTEMS.

NOTE
 SPECIFIC PARTS MAY VARY FROM DIAGRAM

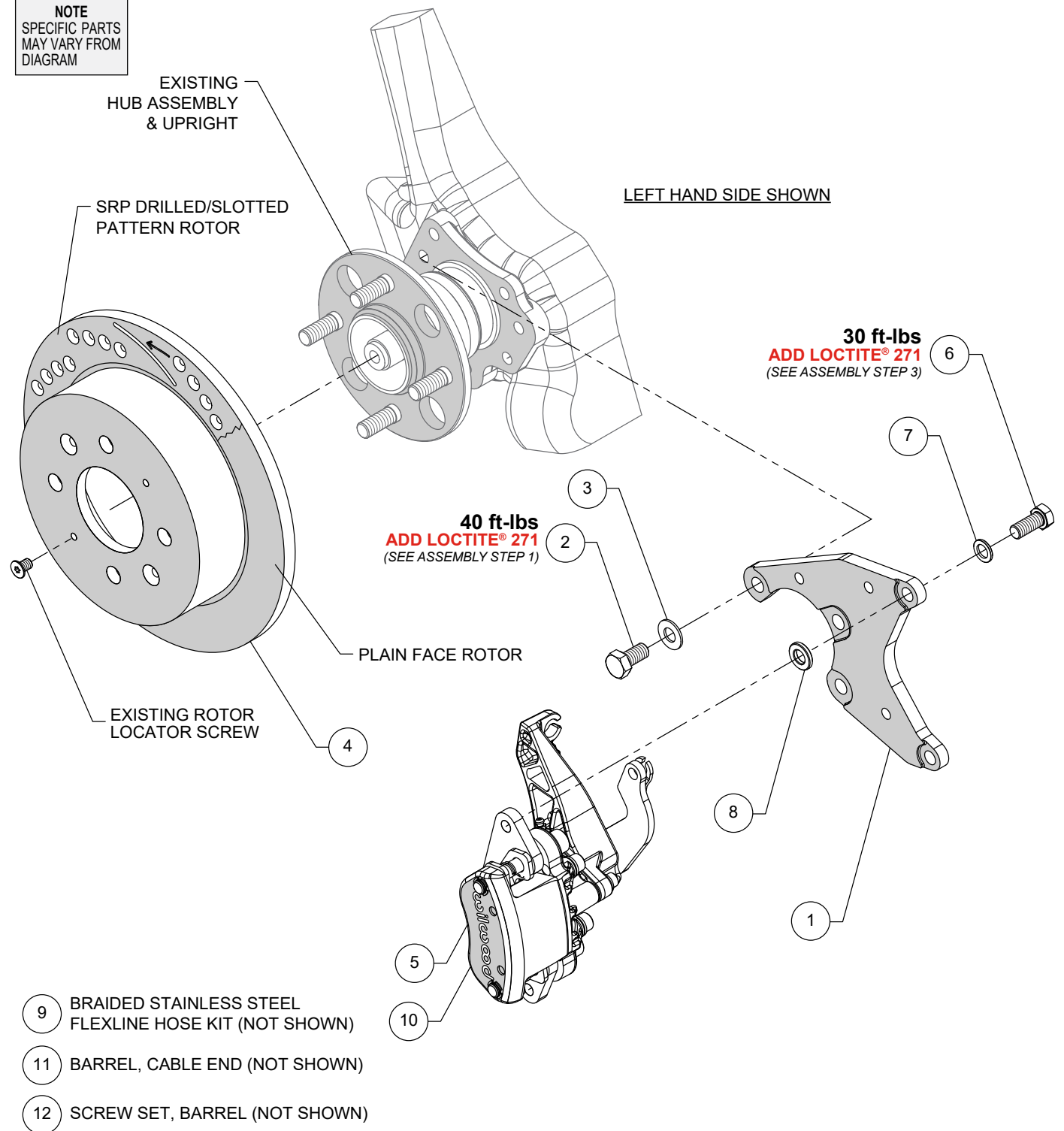

Figure 1. Typical Installation Configuration

Important Notice - Read This First

Before any tear-down or disassembly begins, review the following information:

- Review the Wheel Clearance Diagram on page 2 to verify that there is adequate clearance with the wheels you will be using with the installation.
- This brake kit is not supplied with parking brake cables hardware or adapters. Please see the note in the assembly instructions for part numbers of available Wilwood parking brake cable kits.
- Due to OEM production differences and other variations from vehicle to vehicle, the fastener hardware and other components in this kit may not be suitable for a specific application or vehicle.
- It is the responsibility of the purchaser and installer of this kit to verify suitability / fitment of all components and ensure all fasteners and hardware achieve complete and proper engagement. Improper or inadequate engagement can lead to component failure.

Photographic Tip

Important and highly recommended: Take photos of brake system before disassembly and during the disassembly process. In the event, trouble-shooting photos can be life savers. Many vehicles have undocumented variations, photos will make it much simpler for Wilwood to assist you if you have a problem.

Parts List

<u>ITEM NO.</u>	<u>PART NO.</u>	<u>DESCRIPTION</u>	<u>QTY</u>
1	249-18334/35	Bracket, Caliper Mounting (one each, right & left)	2
2	230-10244	Bolt, M10-1.25" x 20mm Long	6
3	240-17663	Washer, M10, 18mm O.D. x 1.6mm Thick	6
4	162-18336	Rotor, 9.37" Diameter x .39" Thick, 4 x 3.94" Bolt Circle	2
4A	162-18336-BKL/BKR	Rotor, SRP Drilled & Slotted (one each, right & left)	2
5	120-18337/38-BK	Caliper, HM7, Black	2
5A	120-18337/38-RD	Caliper, HM7, Red	2
6	230-15836	Bolt, 3/8-24 x .875", Torx Head	4
7	240-10190	Washer, .391" I.D. x 625" O.D. x .063" Thick	4
8	300-18270	Spacer, .125" Thick	4
9	220-10840	Braided Stainless Steel Flexline Hose Kit (not shown)	1
10	150-8990	Pad, Brake (included in caliper assembly)	4
11	300-17522	Barrel, Cable End	2
12	230-17523	Screw Set, Barrel	2

NOTES:

Part Number 230-10218 Axle Bolt Kit, includes p/ns 230-10244 and 240-17663

Part Number 230-18339 Bracket Kit, includes p/ns 230-15836, 240-10190 and 300-18270

Part Number 330-17540 Cable End Kit, includes p/ns 230-17523, 300-17522 and 330-11486 (not used)

Item 4A is an optional item included with the "-D" drilled rotor kits. Add "-D" to end of part number when ordering.

Item 5A is an optional item included with the "-R" red caliper kits. Add "-R" to end of part number when ordering.

General Information

• Installation of this kit should **ONLY** be performed by persons experienced in the installation and proper operation of disc brake systems. Before assembling the Wilwood disc brake kit, double check the following items to ensure a trouble-free installation.

Make sure this is the correct kit to fit the exact make and model year of your vehicle. This rear parking brake kit is designed for

direct bolt-on installation to 1988 to 2004 Honda rear drum brake applications.

Inspect the contents of this kit against the parts list to ensure that all components and hardware are included.

Verify your wheel clearance using the Wheel Clearance Diagram on page 2.

Disassembly Instructions

• Disassemble the original equipment rear brakes:

Raise the rear wheels off the ground and support the rear suspension according to the vehicle manufacturer's instructions.

Remove the rear wheels, drum brake assembly, and flexlines, .

• Remove any nicks or burrs on the hub face and caliper mounting bosses of upright that may interfere with the installation of the new brake components.

• Clean and -grease the hub and caliper mounting bosses.

Assembly Instructions

IMPORTANT:

- To ensure maximum performance from your parking brake system, the cables must be routed as straight as possible. Bends in the cable can significantly reduce efficiency and thus reduce pull force at the brake. Tight bends must be avoided with a minimum recommended bend radius of 6" to 8".
- Cables should be properly restrained to prevent "straightening" of bends when tension is applied. Restrain movement of cable by affixing the cable sheath to body or chassis by fitting cable clamps at various points over the length of cable or by using original equipment cable attachments points. The clamping method chosen will require that cable sheath be held tightly without movement, crushing or causing interference to the internal cable.
- Cables must be initially pre-stretched by multiple applications of the brake handle, then re-adjusted to correct tension.

NOTE: Numbers in parenthesis refer to the parts list and Figure 1 on the preceding pages.

STEP 1 The caliper mount bracket (1) should initially be installed with clean, dry threads on the mounting bolts. Orient the bracket, as shown in Figure 1 and Photo 1, and install using bolts (2) and washers (3). **NOTE:** The bracket must fit squarely against the mount bosses on the upright. Inspect for interference from casting irregularities, machining ridges, burrs, etc. Apply red Loctite® 271 to the bolt threads (2) and torque to value shown in Figure 1.



Photo 1



Photo 2

STEP 2 Slide the rotor (4) onto the hub. **NOTE:** The rotor must fit flush against the hub flange or excessive rotor run out may result. Install the existing rotor locator screw to keep the rotor in place while continuing with the installation, Photo 2.

STEP 3 Orient the brake caliper (5), as shown in Figure 1, and install using bolts (6) and washers (7). Place one .125" thick spacer (8) on each bolt between the bracket (1) and parking brake caliper (5) as shown in Figure 1. Apply red Loctite® 271 to the threads, and torque to value shown in Figure 1.

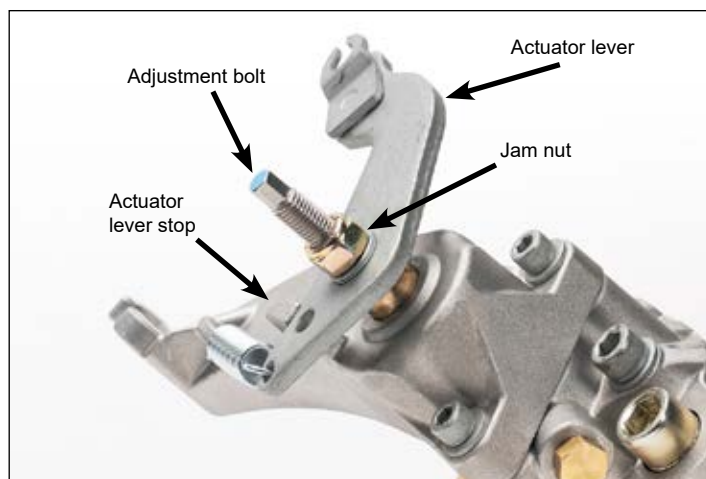

Photo 3

Adjust Parking Brake:

1. Loosen adjustment bolt jam nut on the backside of parking brake caliper assembly, see Photo 3.
2. Tighten the adjustment bolt until there is some drag on the rotor.
3. Back off adjustment bolt one-half turn.
4. Ensure there is no rotation of adjustment bolt while tightening jam nut to **80-120 in-lb**.
5. Check for drag on rotor. A slight rubbing sound during rotation is acceptable.

STEP 4 Temporarily install the wheel and torque the lug nuts to the manufacturer's specification. Ensure that the wheel rotates freely without any interference. Remove wheel for next step.

STEP 5 Attach brake line to caliper. Install Wilwood's braided stainless steel flexline hose kit (9), P/N 220-10840, included with this kit. Route brake line as shown in Photo 4. Install and secure the included grommet and flexline bracket using existing OEM bolt and location, Photo 5. Connect flexline to caliper using banjo bolt and crush washers, Photo 6. Note final orientation of banjo fitting. Do not use thread sealant on banjo bolt. Torque to **96-120 in-lbs**, do not exceed **144 in-lbs**. Check for leakage, increasing torque only to stop



Photo 4

Assembly Instructions (Continued)

leakage without exceeding maximum specification. Replace crush washers and banjo bolt whenever reassembly is required. **Ensure hoses are routed to prevent contact with moving suspension, brake or wheel components.**

•**CAUTION:** In absence of specific instructions for brake line routing, the installer must use his best professional judgment on correct routing and retention of lines to ensure safe operation. It is the installer's responsibility to ensure that all fittings and hoses are the correct size and length, properly seal, and that they will not be subject to crimping, strain and abrasion from vibration or interference with suspension components, brake rotor or wheel.

STEP 6 Bleed the brake system, referring to the 'Additional Information and Recommendations' below for proper bleeding instructions. Check system for leaks after bleeding.

STEP 7 Install parking brake cables. **NOTE:** The OEM parking brake cables will not work with the Wilwood brake caliper. Wilwood offers the following parking brake cable kits, **sold separately:**

- For 1990-2004 Honda CRX: P/N 330-9371
- For 1990-2004 Honda Civic: P/N 330-9371

STEP 8 Use the following vehicle specific instructions to install the 330-9371 universal parking brake cable kit.

1. Starting with one cable. Start at the caliper end, insert the inner cable into the cable housing and feed it all the way through. Repeat for second cable.
2. Attach cable and housing end to the HM7 caliper (5), Figure 2. Do not yet insert cable barrel end into caliper actuating lever.
3. Following the approximate OEM cable routing, route the new cable from the caliper to the hand lever inside the vehicle, Photo 7. **Carefully route cable to prevent contact with exhaust or moving suspension, brake, or wheel components.** It's the installer's responsibility to properly route and ensure adequate clearance and retention for parking brake cable components.
4. Use cable clamps from cable kit to secure cables to vehicle chassis, Photo 7.
5. Trim cable housing length to fit OEM cable bracket location (inside vehicle) being sure to maintain enough length for housing end to bottom out inside OEM cable bracket, Photo 10. Then slide housing ferrule into adjuster nut, Photo 8. **NOTE: Put a little red Loctite® 271 on ferrule before inserting to help hold it in the adjuster nut.**
6. Set the adjuster nuts on the new cables to approximately the middle of the threaded adjustment range, Photo 10.
7. Install and tighten jam nuts on balance bar side of the OEM cable bracket, Photo 10.



Photo 5



Photo 6

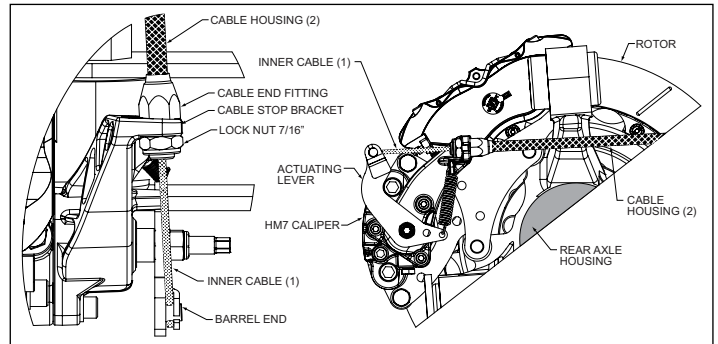

Figure 2. Typical Installation, HM7 Parking Brake Caliper

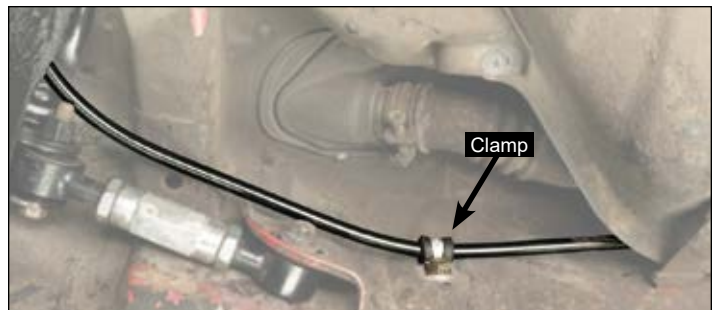

Photo 7

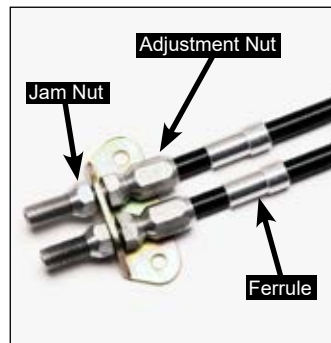

Photo 8

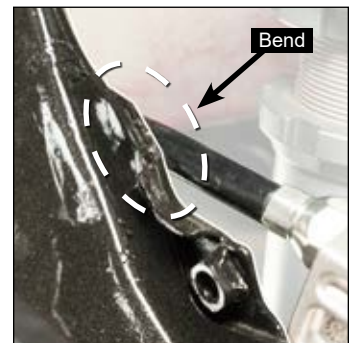

Photo 9

8. Repeat the previous steps on the other side of the vehicle. Continue with the installation after you have both cables routed.
9. **NOTE:** The trailing arm flange may need to be slightly bent or modified so it does not deflect the cable near the caliper, Photo 9.

Assembly Instructions (Continued)

STEP 9 The cable end kit P/N 330-17540 included in this brake kit is utilized with Wilwood parking brake kit P/N 330-9371

1. Insert cable barrel end into HM7 caliper (5) actuating lever Figure 2.
2. Be sure the hand lever is in the fully released position.
3. Set the OEM adjuster nut to approximately the middle of the adjustment range, Photo 10.
4. Thread both inner cables through the OEM balance bar and cut off excess cable length, Photo 10.
5. Slide barrels (10) & set screws (11) onto inner cables and insert barrels into OEM balance bar, Photo 10.
6. Remove the slack by pulling the inner cables through the OEM balance bar and tightening the barrel set screws.
NOTE: When pulling on the cables to remove the slack, be sure **not** to actuate the caliper lever(s) (at the wheels).
7. Remove one set screw at a time, apply blue *Loctite*® to thread, and torque to **35 in-lbs**.
8. Final adjustments are performed at the threaded portion of the OEM cable bracket by loosening jam nuts and turning adjuster nuts.
9. Adjust as needed so the OEM balance bar is even (perpendicular to the cable pull direction), Photo 10.
NOTE: The parking levers (at the wheels) should remain at the fully released position when all adjustments are complete.

STEP 10 Install the wheel and torque the lug nuts to manufacturer's specifications.

•CAUTION: Test vehicle brake system per the **'Minimum Test Procedure'** stated within this document before driving. After road testing, inspect for leaks and interference. Initially after install and testing, perform frequent checks of the vehicle brake system and lines before driving, to confirm that there is no undue wear or interference not apparent from the initial test. Afterwards, perform periodic inspections for function, leaks and wear in an interval relative to the usage of vehicle.

STEP 11 Bed-in the brake pads per the procedure on page 9.

CAUTION: After bleeding and bedding the brakes per the brake kit installation instructions, carefully test the holding power of the parking brakes. Test parking brake in a safe area, first on a flat surface by pushing on the vehicle, then on a slight incline by applying and releasing handle multiple times. See **Warning** on last page of this document.

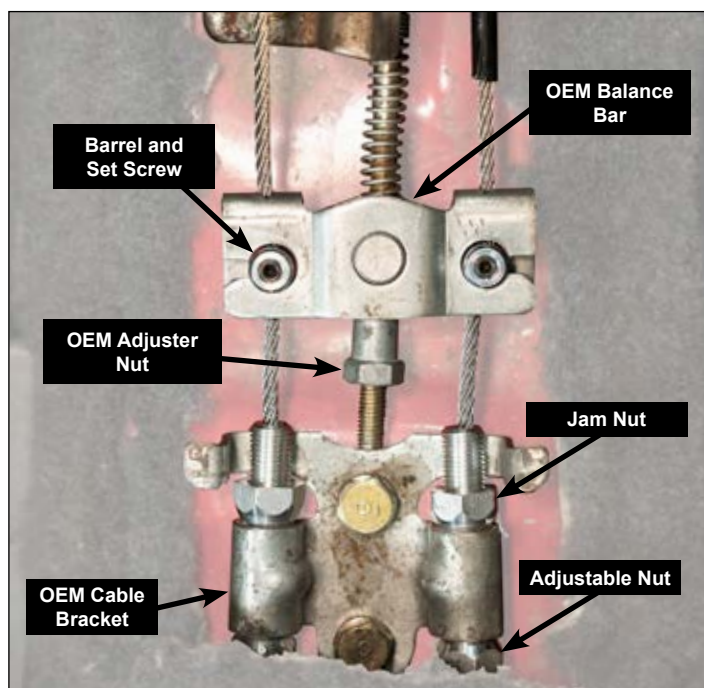

Photo 10



Assembled Brake Kit

Additional Information and Recommendations

- Fill and bleed the new system with Wilwood Hi-Temp° 570 grade fluid or higher. For severe braking or sustained high heat operation, use Wilwood EXP 600 Plus Racing Brake Fluid. Used fluid must be completely flushed from the system to prevent contamination.
NOTE: *Silicone DOT 5 brake fluid is **NOT** recommended for racing or performance driving.*
 - To properly bleed the brake system, begin with the caliper farthest from the master cylinder. Bleed the outboard bleed screw first, then the inboard. Repeat the procedure until all calipers in the system are bled, ending with the caliper closest to the master cylinder.
NOTE: *When using a new master cylinder, it is important to bench bleed the master cylinder first.*
 - Test the brake pedal. It should be firm, not spongy and stop at least 1 inch from the floor under heavy load.
 - If the brake pedal is spongy, bleed the system again.
 - If the brake pedal is initially firm, but then sinks to the floor, check the system for fluid leaks. Correct the leaks (if applicable) and then bleed the system again.
 - If the brake pedal goes to the floor and continued bleeding of the system does not correct the problem, a master cylinder with increased capacity (larger bore diameter) will be required. Wilwood offers various lightweight master cylinders with large fluid displacement capacities.
- **NOTE:** *With the installation of aftermarket disc brakes, the wheel track may change depending on the application. Check your wheel offset before final assembly.*

Brake Testing

**WARNING • DO NOT DRIVE ON UNTESTED BRAKES
BRAKES MUST BE TESTED AFTER INSTALLATION OR MAINTENANCE
MINIMUM TEST PROCEDURE**

- Make sure pedal is firm: Hold firm pressure on pedal for several minutes, it should remain in position without sinking. If pedal sinks toward floor, check system for fluid leaks. DO NOT drive vehicle if pedal does not stay firm or can be pushed to the floor with normal pressure.
- At very low speed (2-5 mph) apply brakes hard several times while turning steering from full left to full right, repeat several times. Remove the wheels and check that components are not touching, rubbing, or leaking.
- Carefully examine all brake components, brake lines, and fittings for leaks and interference.
- Make sure there is no interference with wheels or suspension components.
- Drive vehicle at low speed (15-20 mph) making moderate and hard stops. Brakes should feel normal and positive. Again check for leaks and interference.
- Always test vehicle in a safe place where there is no danger to (or from) other people or vehicles.
- Always wear seat belts and make use of all safety equipment.

Pad and Rotor Bedding

BEDDING STEPS FOR NEW PADS AND ROTORS – ALL COMPOUNDS

Once the brake system has been tested and determined safe to operate the vehicle, follow these steps for the bedding of all new pad materials and rotors. These procedures should only be performed on a racetrack, or other safe location where you can safely and legally obtain speeds up to 65 MPH, while also being able to rapidly decelerate.

- Begin with a series of light decelerations to gradually build some heat in the brakes. Use an on-and-off the pedal technique by applying the brakes for 3-5 seconds and then allow them to fully release for a period roughly twice as long as the deceleration cycle. If you use a 5 count during the deceleration interval, use a 10 count during the release to allow the heat to sink into the pads and rotors.
- After several cycles of light stops to begin warming the brakes, proceed with a series of medium to firm deceleration stops to continue raising the temperature level in the brakes.
- Finish the bedding cycle with a series of 8-10 hard decelerations from 55-65 MPH down to 25 MPH while allowing a proportionate release and heat-sinking interval between each stop. The pads should now be providing positive and consistent response.
- If any amount of brake fade is observed during the bed-in cycle, immediately begin the cool down cycle.
- Drive at a moderate cruising speed, with the least amount of brake contact possible, until most of the heat has dissipated from the brakes. Avoid sitting stopped with the brake pedal depressed to hold the car in place during this time. Park the vehicle and allow the brakes to cool to ambient air temperature.

COMPETITION VEHICLES

- If your race car is equipped with brake cooling ducts, blocking them will allow the pads and rotors to warm up quicker and speed up the bedding process.
- Temperature indicating paint on the rotor and pad edges can provide valuable data regarding observed temperatures during the bedding process and subsequent on-track sessions. This information can be highly beneficial when evaluating pad compounds and cooling efficiencies.

POST-BEDDING INSPECTION – ALL VEHICLES

- After the bedding cycle, the rotors should exhibit a uniformly burnished finish across the entire contact face. Any surface irregularities that appear as smearing or splotching on the rotor faces can be an indication that the brakes were brought up to temperature too quickly during the bedding cycle. If the smear doesn't blend away after the next run-in cycle, or if chatter under braking results, sanding or resurfacing the rotors will be required to restore a uniform surface for pad contact.

PRE-RACE WARM UP

- Always make every effort to get heat into the brakes prior to each event. Use an on-and-off the pedal practice to warm the brakes during the trip to the staging zone, during parade laps before the flag drops, and every other opportunity in an effort to build heat in the pads and rotors. This will help to ensure best consistency, performance, and durability from your brakes.

DYNO BEDDED COMPETITION PADS AND ROTORS

- Getting track time for a proper pad and rotor bedding session can be difficult. Wilwood offers factory dyno-bedded pads and rotors on many of our popular competition pads and **Spec 37** GT series rotors. Dyno-bedded parts are ready to race on their first warm up cycle. This can save valuable time and effort when on-track time is either too valuable or not available at all, Dyno-bedding assures that your pads and rotors have been properly run-in and are ready to go. Contact your dealer or the factory for more information on Wilwood Dyno-Bedding services.

NOTE: NEVER allow the contact surfaces of the pads or rotors to be contaminated with brake fluid. Always use a catch bottle with a hose to prevent fluid spill during all brake bleeding procedures.

Parking Brake

WARNING • PARKING BRAKE

- Parking brake must be properly adjusted before use and must be manually readjusted for wear if parking brake handle or foot lever travel becomes excessive.
- The holding ability of the brake should be tested by stopping on a sloping surface and applying the parking brake while holding car with the hydraulic foot brake. This should be accomplished both facing up and down hill.
- Do not rely exclusively on the parking brake to hold the car; Curb wheels as recommended by the applicable diagram and put gear selector in park, or shift into first gear or reverse with a manual transmission.

- Diagram A - When parking facing downhill, turn front wheels towards the curb or right shoulder. This will keep from rolling into traffic if the brakes become disengaged.
- Diagram B - Turn the steering wheel to the left so the wheels are turned towards the road if you are facing uphill with a curb. The tires will catch the curb if the car rolls backward.
- Diagram C - When facing uphill without a curb, turn the wheels sharply to the right. If the vehicle rolls, it will go off the road rather than into traffic.
- When parking on a hill, always set the parking brake and move the gear selector into park, or shift into first or reverse gear if your vehicle has a manual transmission.

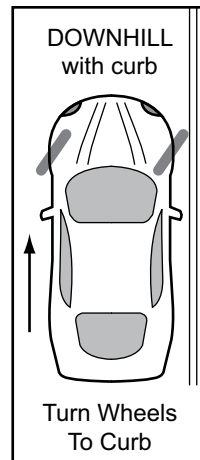

Diagram A

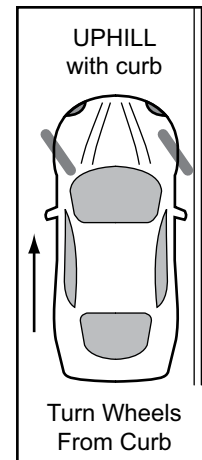

Diagram B

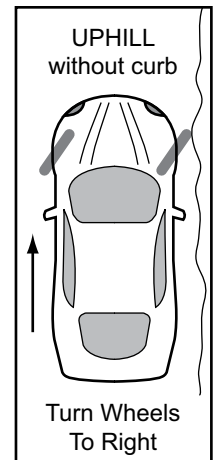

Diagram C

Connect with Wilwood

