

The GP 200 billet aluminum caliper was designed to be a lightweight (less than 1 lb) solution for applications with limited space while utilizing a standard 2.38" lug mount. Centrally located inlet, four corner bleed screws and internal fluid crossover allow one caliper to work in front, rear, left, or right side positions.

Strengthening just the critical areas of the caliper decreases deflection and body separation under load without increasing mass, as proven by volume displacement testing. The result is a firm, responsive pedal with superior stopping power.

Widely used in college formula SAE vehicles, mini sprint, 600 mini sprint, small formula car classes, and other unique applications, its size and design make it a great option.

#### CALIPER FEATURES:

- CNC machined body from premium grade billet aluminum, Type III hard anodized to reduce internal wear
- Finite Element Analysis designed for strength with optimized transition from piston housing to bridge
- Decreased deflection and body separation under load without increased mass, as proven by volume displacement testing

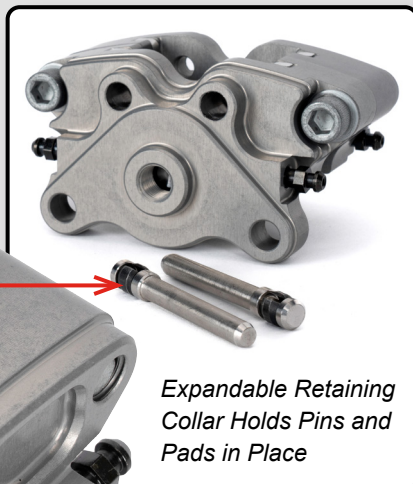

*Expandable Retaining Collar Holds Pins and Pads in Place*



- Heavy wall stainless steel pistons resist corrosion, slow heat transfer to fluid, and eliminate backside deflection at high system pressure
- New punch-in retaining pins feature an expandable collar to hold in place, and simplify pad changes

**P/N 120-17702** with central 1/8"-27 NPT inlet and logo intended for mounting above the axle

**P/N 120-16888** with central 3/8"-24 straight inlet and logo inverted for mounting below the axle

## GP200 Caliper Mounting Dimensions

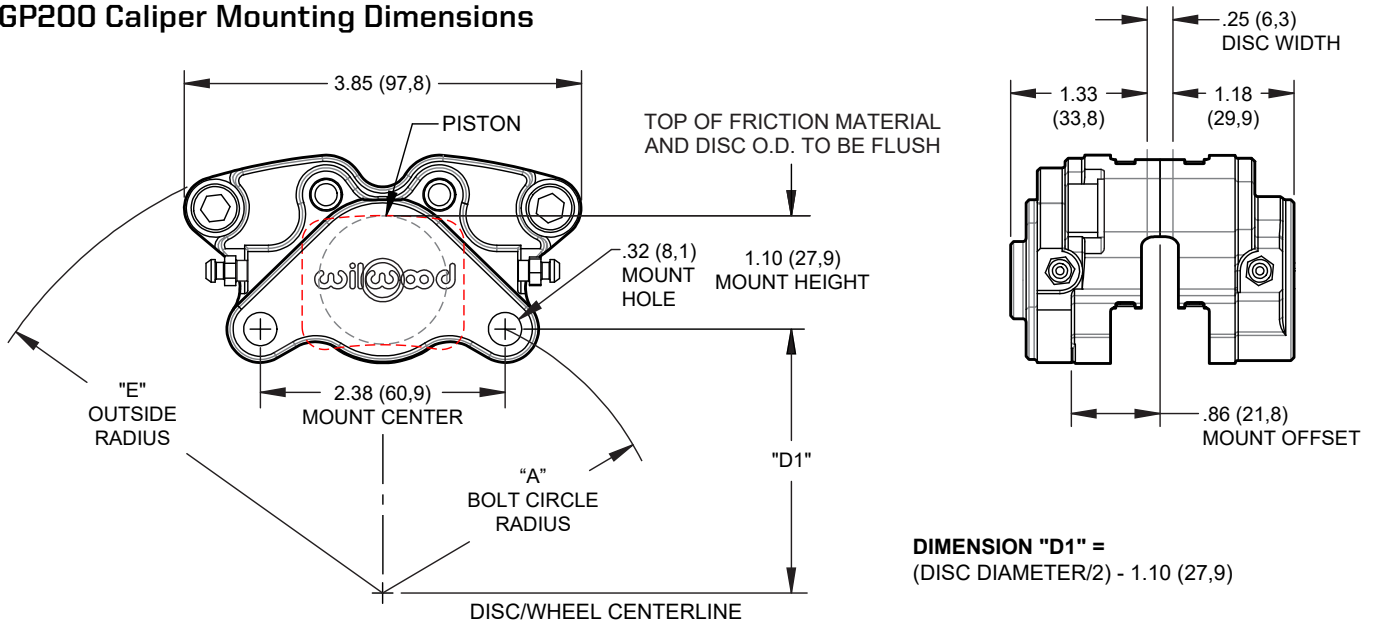

PART NO.	INLET FITTING
120-17702	1/8-27 NPT
120-16888	3/8-24 STRAIGHT

**WARNING**  
INSTALLATION OF THIS KIT SHOULD ONLY BE PERFORMED BY PERSONS EXPERIENCED IN THE INSTALLATION AND PROPER OPERATION OF DISC BRAKE SYSTEMS.

DISC DIAMETER	"E" OUTSIDE RADIUS	"D1" HEIGHT	"A" BOLT CIRCLE RADIUS
8.00 (203,2)	4.68 (118,9)	2.90 (73,7)	3.13 (79,5)
8.75 (222,2)	5.03 (127,8)	3.28 (83,2)	3.48 (88,4)
10.00 (254,0)	5.62 (142,8)	3.90 (99,1)	4.07 (103,4)
10.50 (266,7)	5.86 (148,9)	4.15 (105,4)	4.31 (109,6)
10.75 (273,0)	5.90 (149,9)	4.28 (108,6)	4.43 (112,6)
11.00 (278,4)	6.10 (155,0)	4.40 (111,8)	4.57 (115,0)

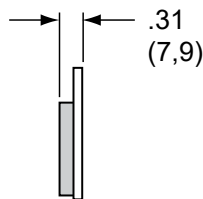
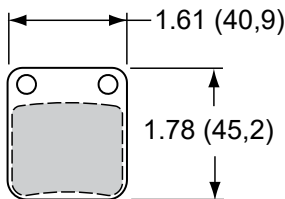

## GP200 Caliper Brake Pads and Ordering Information

PART NUMBER	COMPOUND	PAD TYPE
<a href="#">150-12270K</a>	Purple (for aluminum rotor)	4908
<a href="#">150-28-4908K</a>	BP-28 (racing pad)	4908

## USER SERVICABLE COMPONENTS:

PISTON	SQ RING KIT	BLEED SCREW	BODY SEAL	PAD RETAINING PIN
200-8488 (1.25")	130-3602 (4 pk)	220-7496 (each)	210-2582 (each)	180-17959 (4 pk)

ORDERING INFO: PH: 805.388.1188 • FAX: 805.388.4938 • [wilwood.com](http://wilwood.com) • [info@wilwood.com](mailto:info@wilwood.com)

PART NUMBER	DESCRIPTION	INLET FITTING	FINISH	BORE SIZE
<a href="#">120-17702</a>	GP200 CALIPER, 1.25, .25 ROTOR, 2.375 MT	1/8-27 NPT	Hard Ano	1.25" (31.8)
<a href="#">120-16888</a>	GP200 CALIPER, 1.25, .25 ROTOR, 2.375 MT (Inverted Logo)	3/8-24 STRAIGHT	Hard Ano	1.25" (31.8)